

HIMARS

Дерев'яний 3D конструктор
Wooden 3D Puzzle

THE
GRAVIX
3D PUZZLES

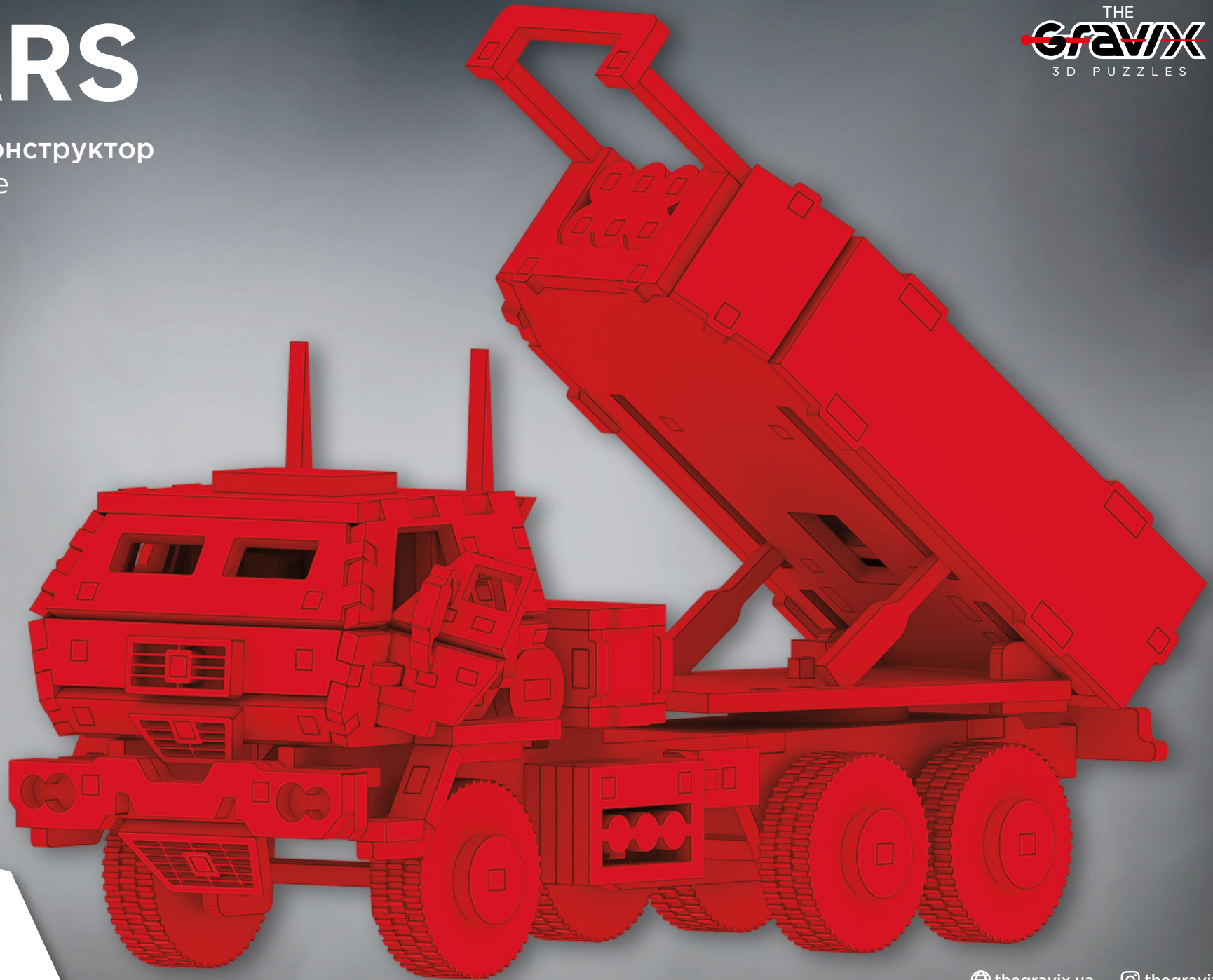

ІНСТРУКЦІЯ
INSTRUCTION

Зверніть увагу!

- 1.** Щоб дістати деталі з планшетки використовуйте допоміжний елемент.
- 2.** Деякі елементи пазлу можуть з'єднуватися із зусиллям.
- 3.** Якщо елемент з'єднується із зусиллям або не входить в паз іншої деталі, то потрібно скористатися пилочкою.
- 4.** Якщо деталь при з'єднанні занадто вільно тримається в пазах конструктора, тоді краще додатково використати клей.
- 5.** Запасні деталі позначені номером в дужках.
- 6.** Будьте уважними, та не поспішайте.

Pay attention!

- 1.** Use the auxiliary element to get the parts from the tablet.
- 2.** Some parts of the puzzle can be connected with force.
- 3.** If the element is connected with difficulty or does not fit into the groove of another part, then you need to use the nail file.
- 4.** If the part is too loose when connected, does not hold in the grooves of the constructor, then it is better to additionally use glue
- 5.** If you see parts marked with a number in parentheses, they are spare.
- 6.** Be careful and take your time.



— Номер планшетки з необхідними деталями. Tablet number with the necessary parts.

1

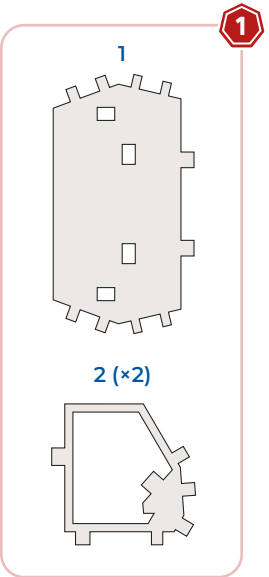
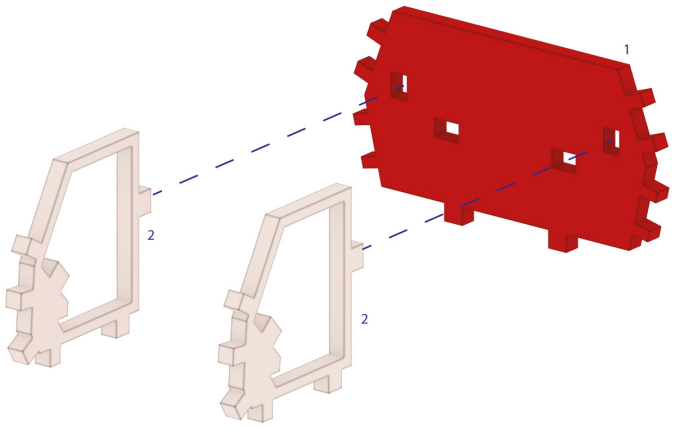

2

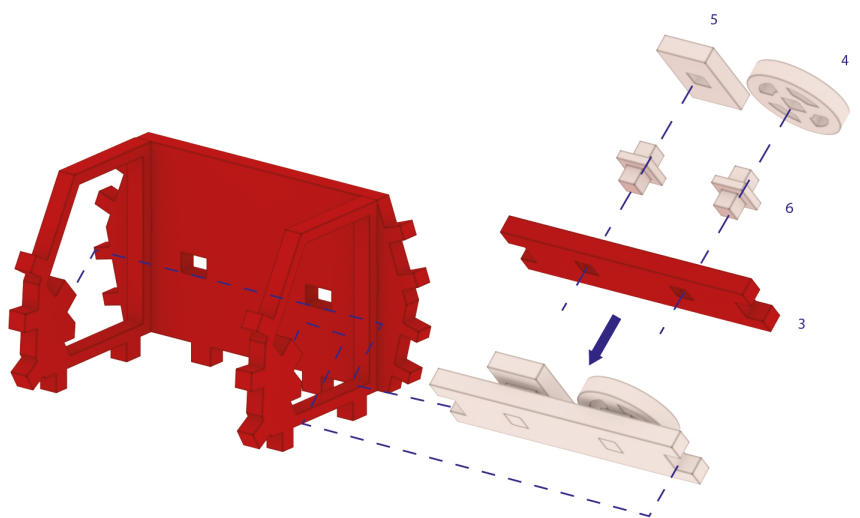
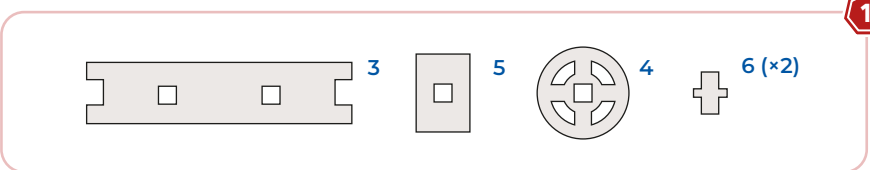

3

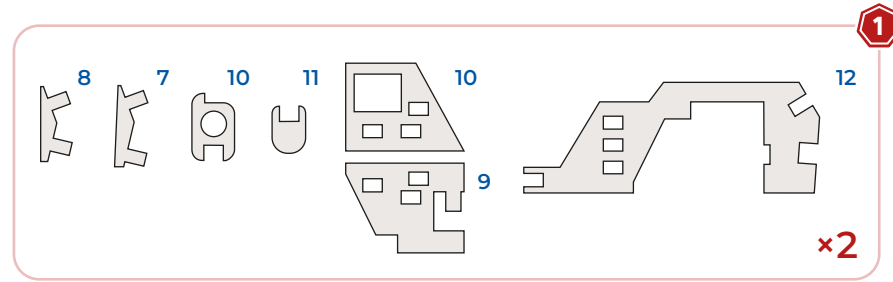

3.1

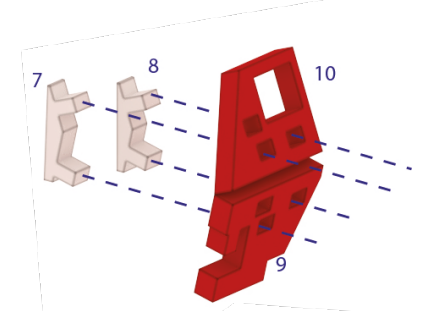
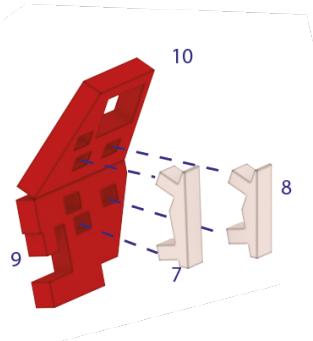

3.2

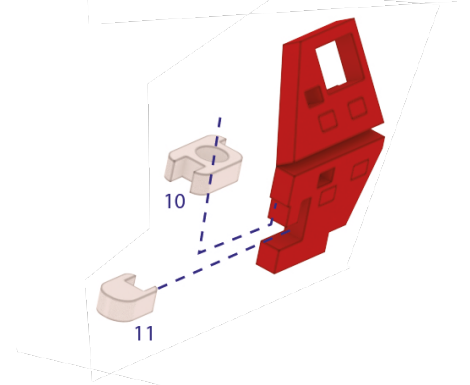
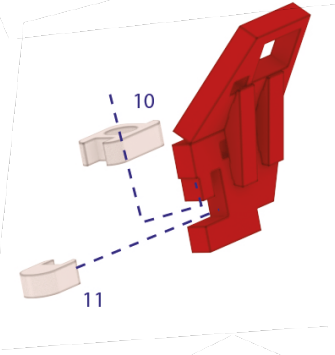

3.3

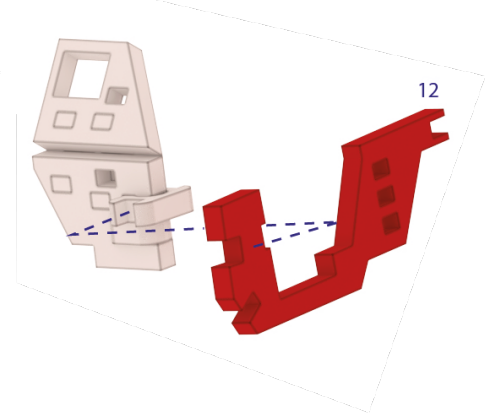
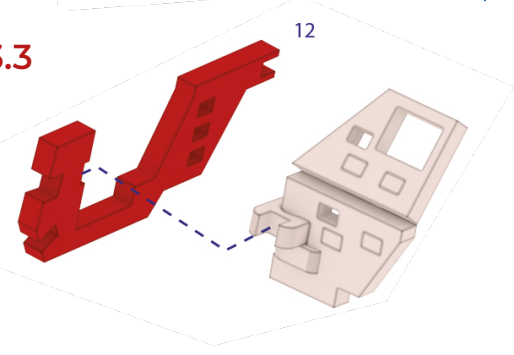

4

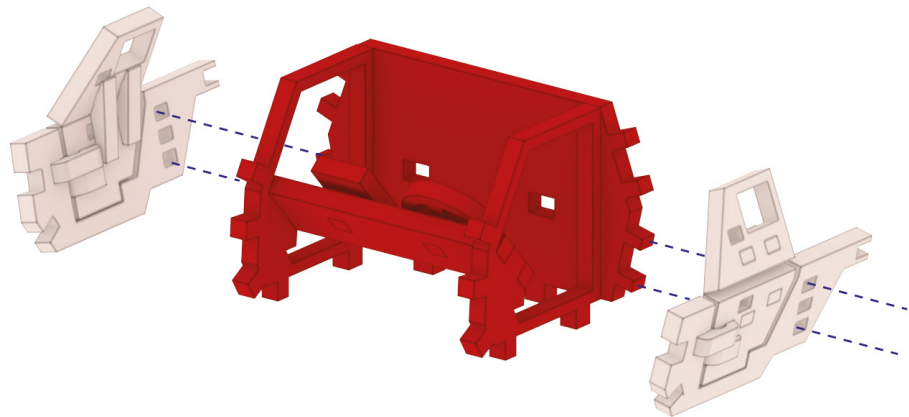

5

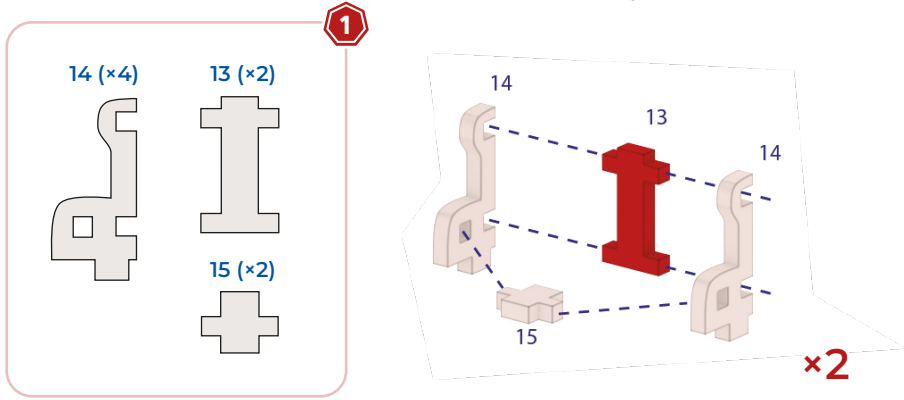

6

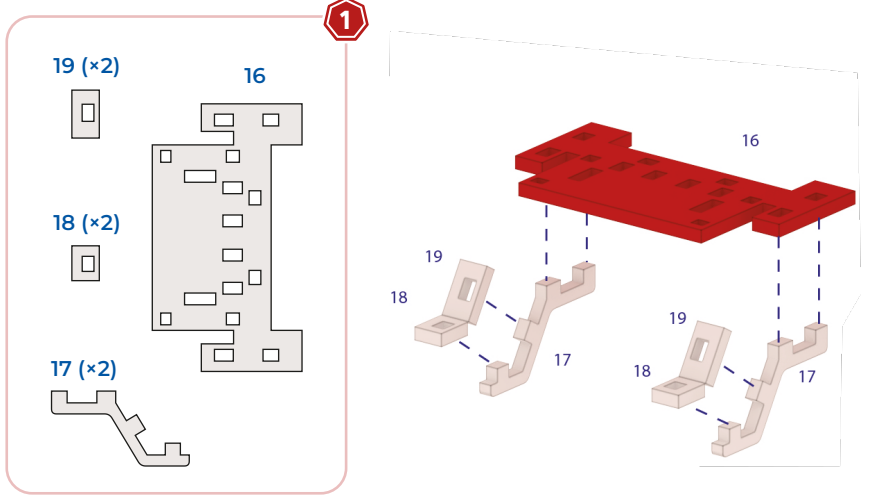

7

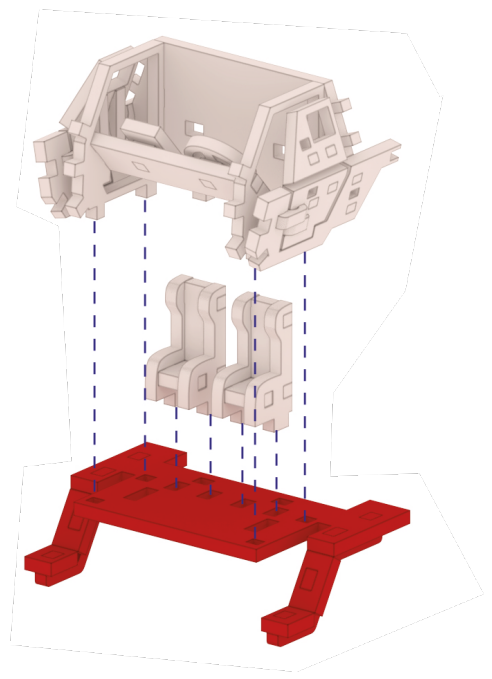

8

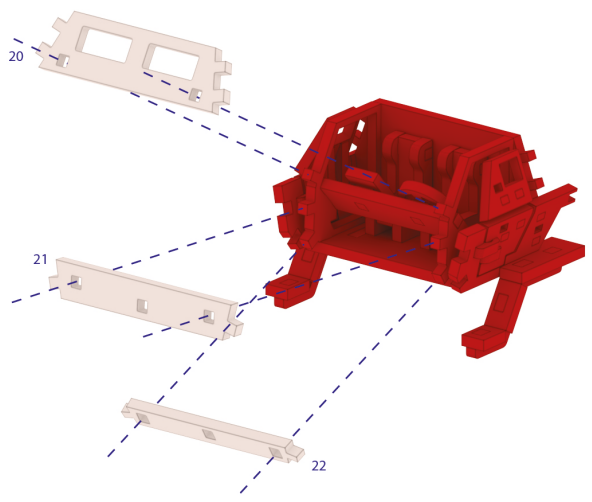
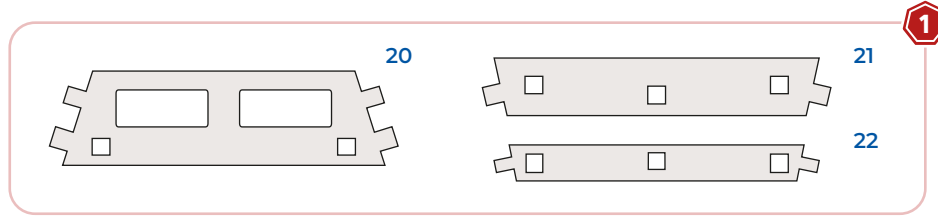

9

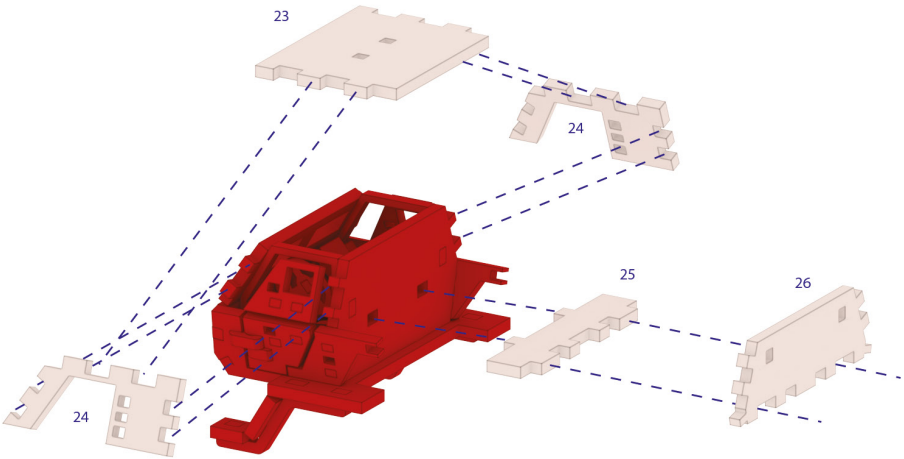
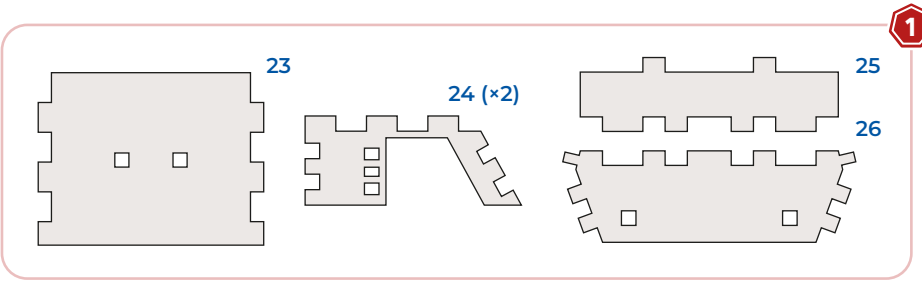

10

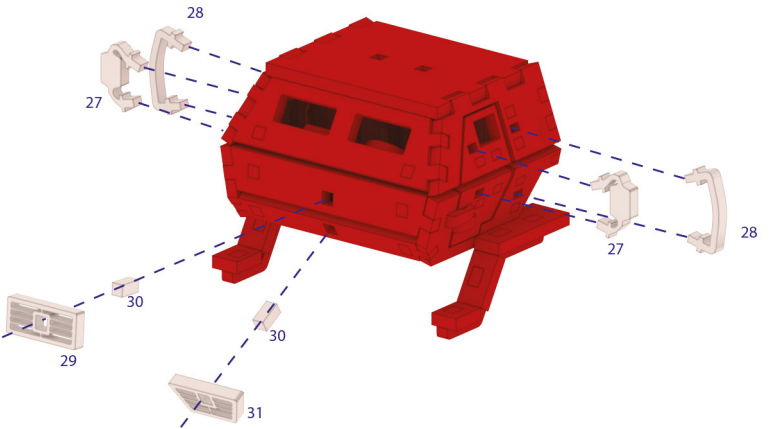
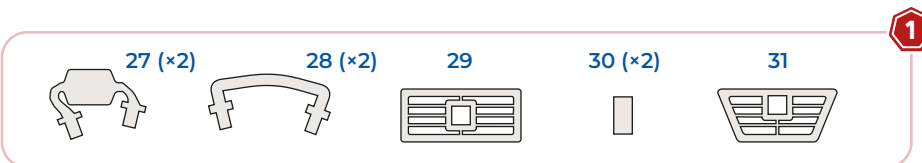

11

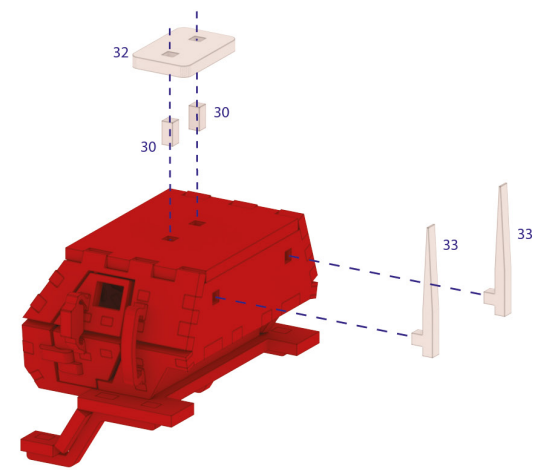
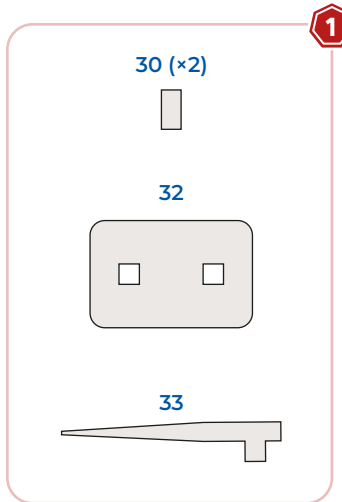

12

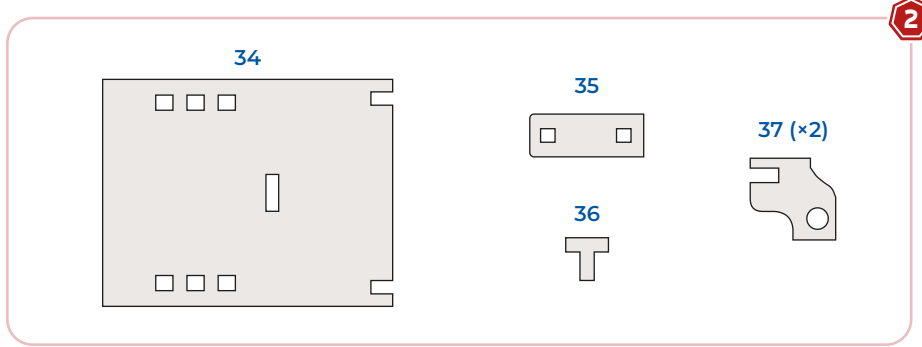

12.1

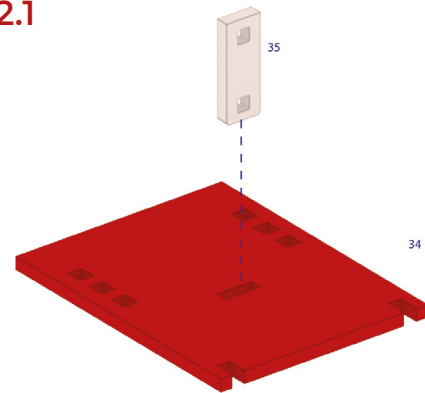

12.2

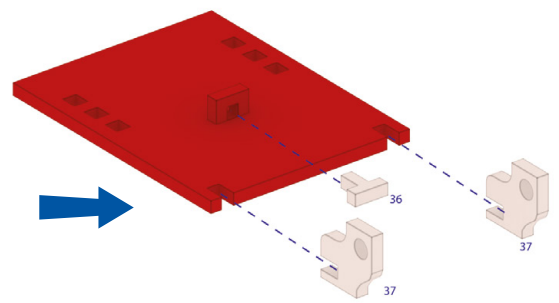

1

1

1

2

13

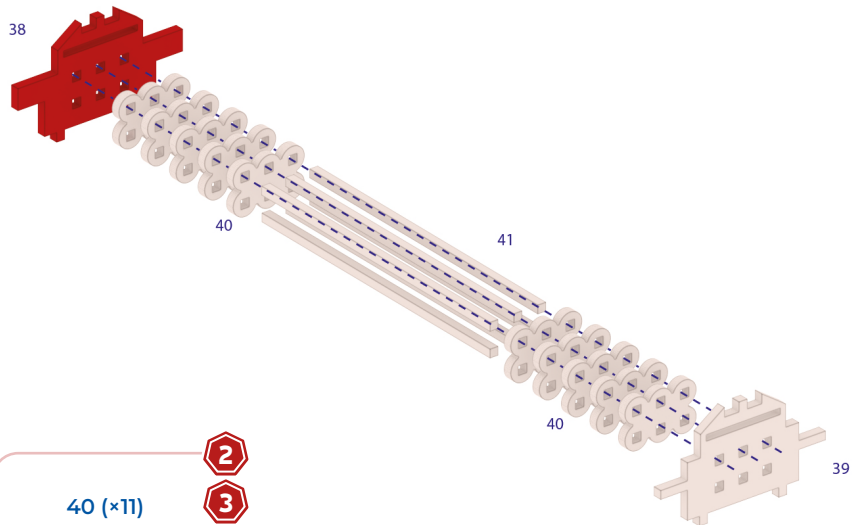
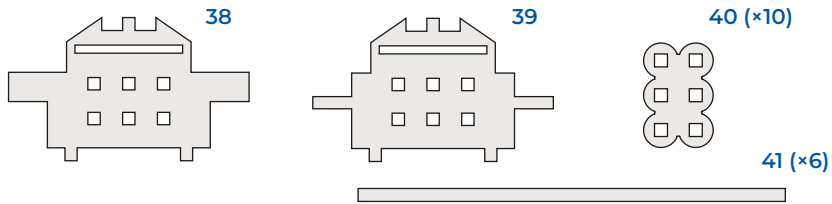

14

40 (x11)

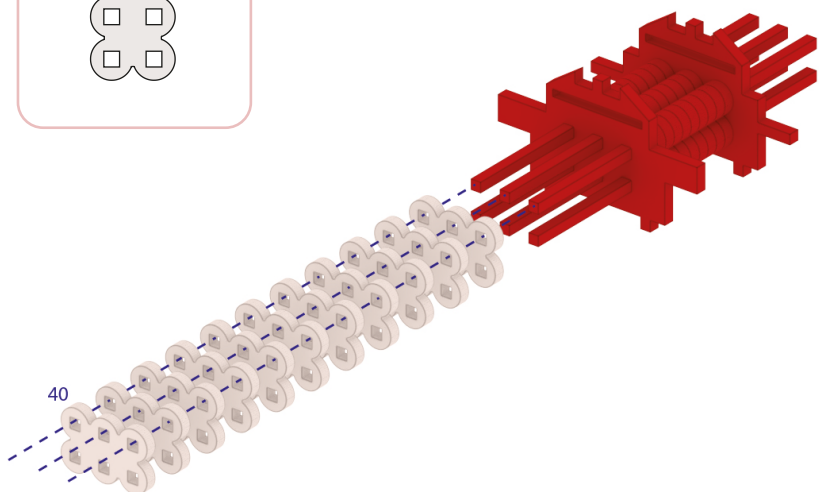
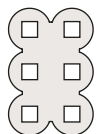

2
3

15

40 (x10)

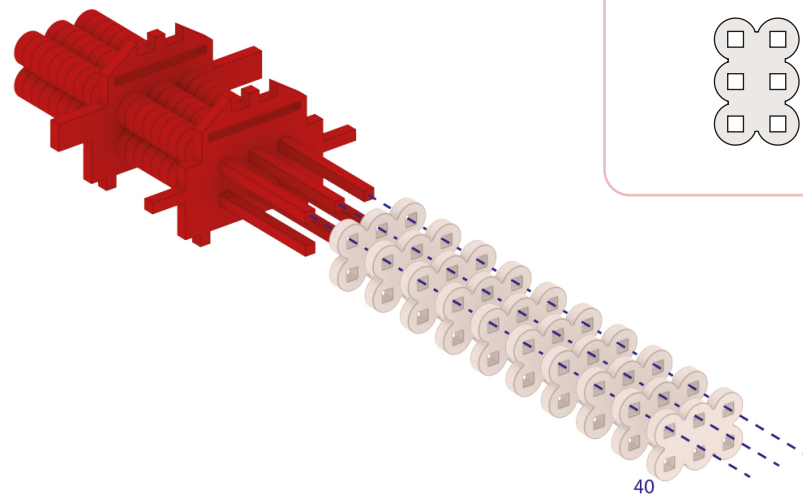
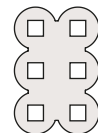

2
3

16

42

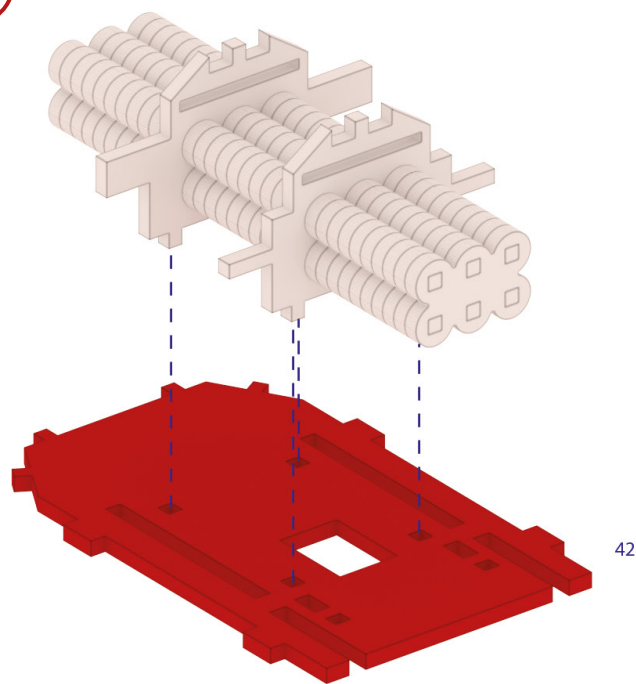
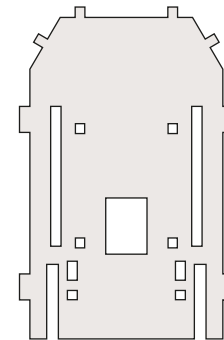

2

17

2

43 (x2)

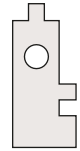

44

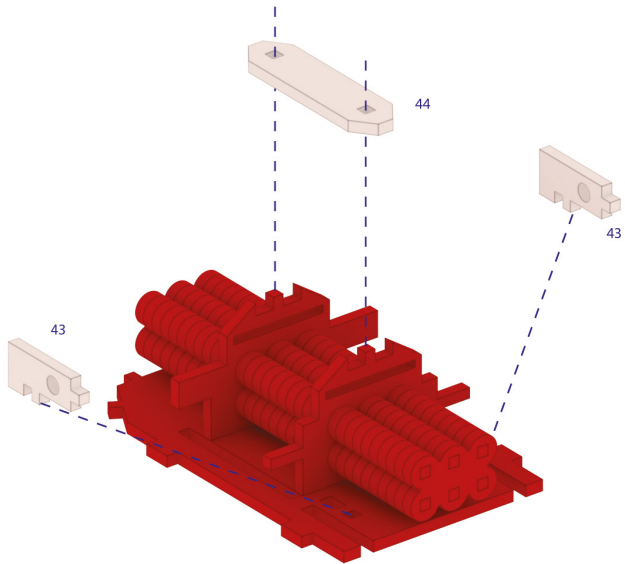

18

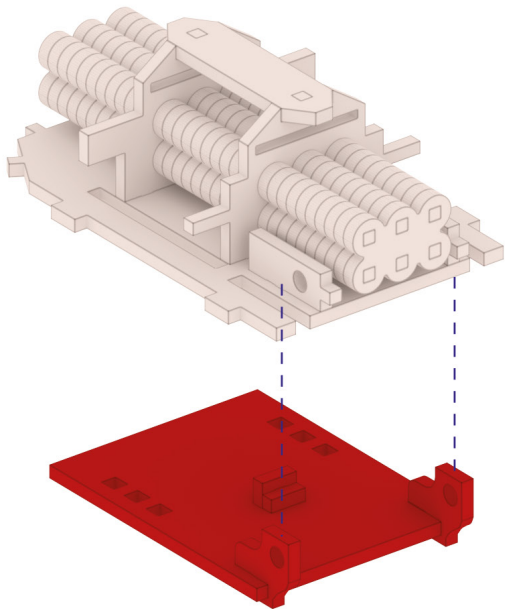

19

2

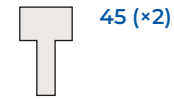

45 (x2)



46 (x2)



47 (x4)

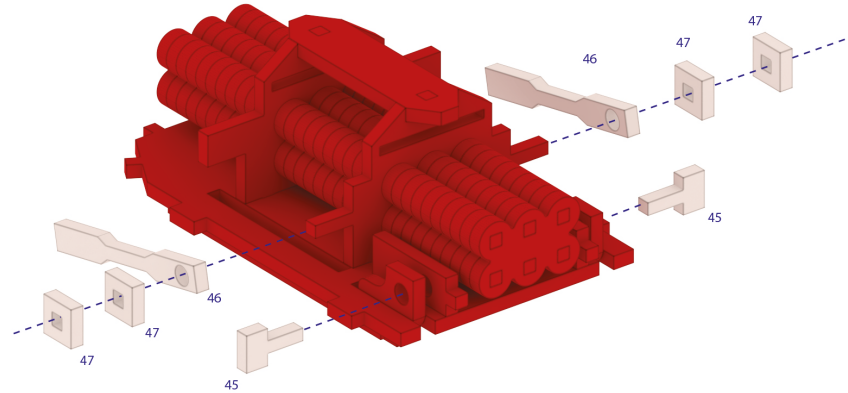

20

2

48 (x2)

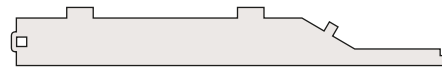

49

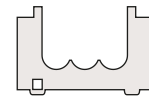

50 (x2)

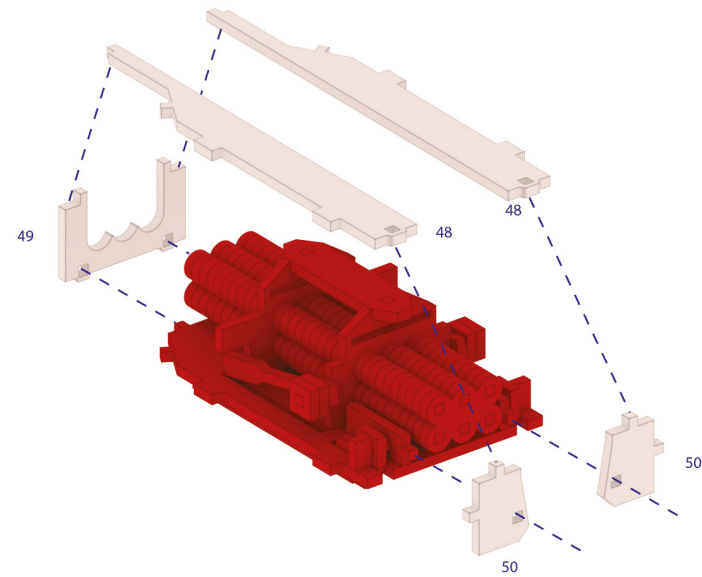

21

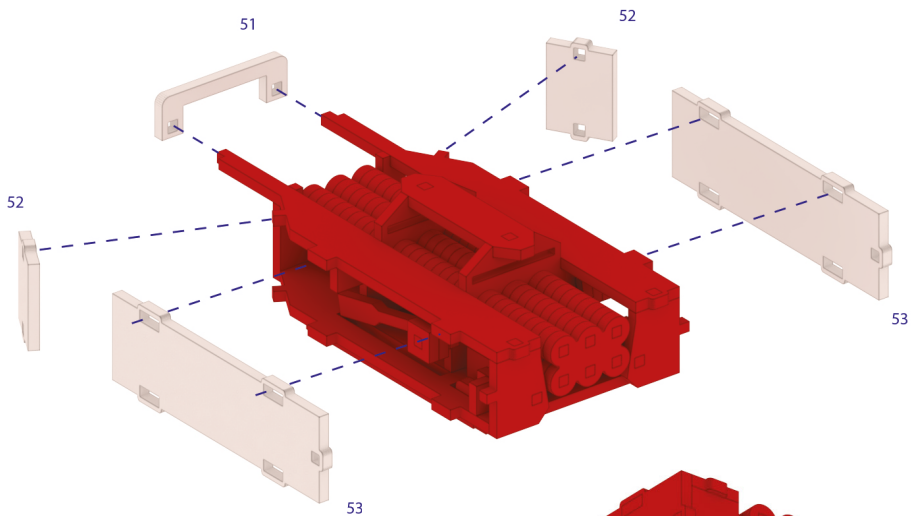
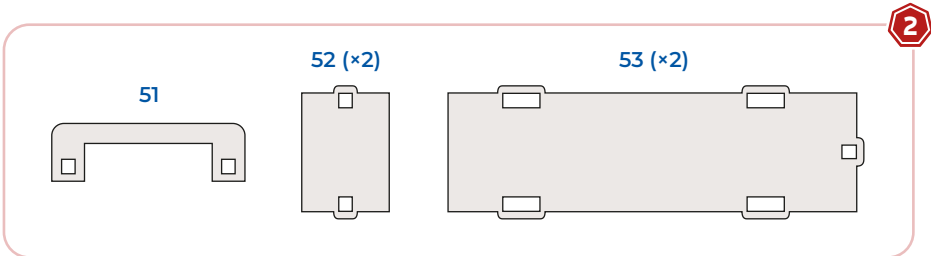

22

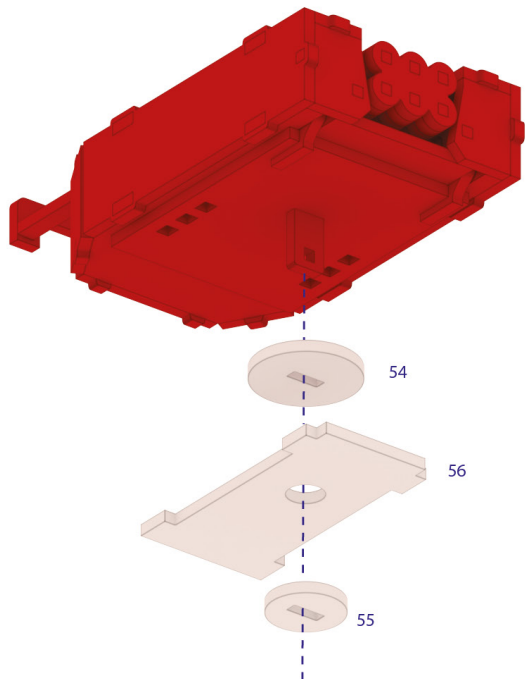
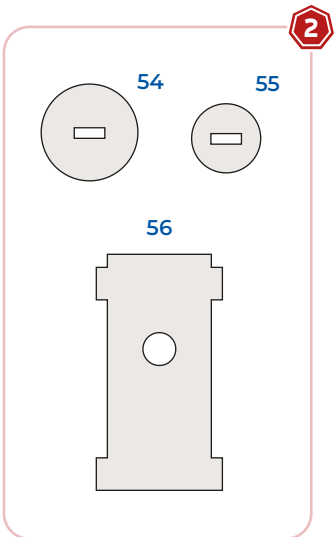

23

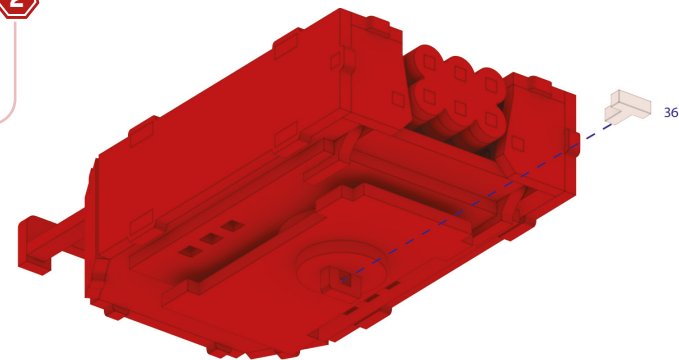
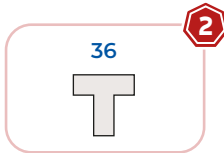

24

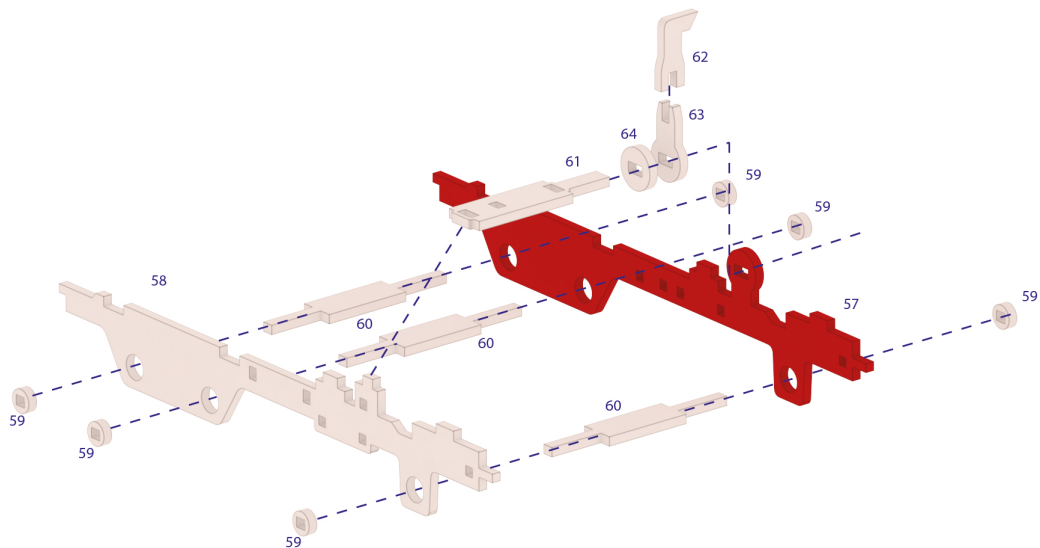
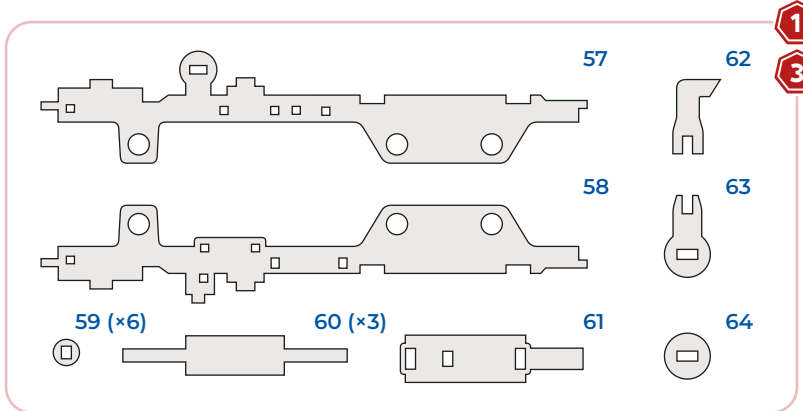

25

3

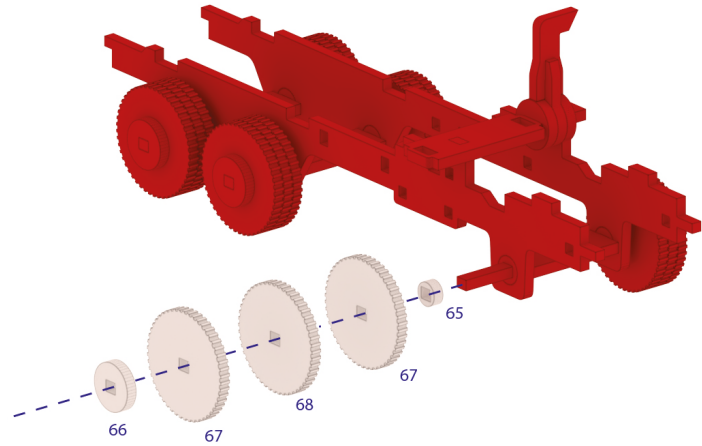
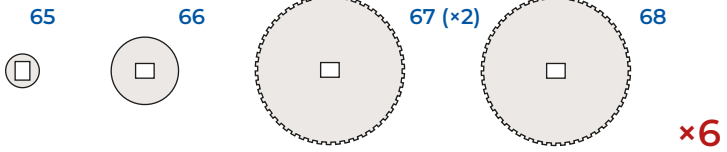

26

2

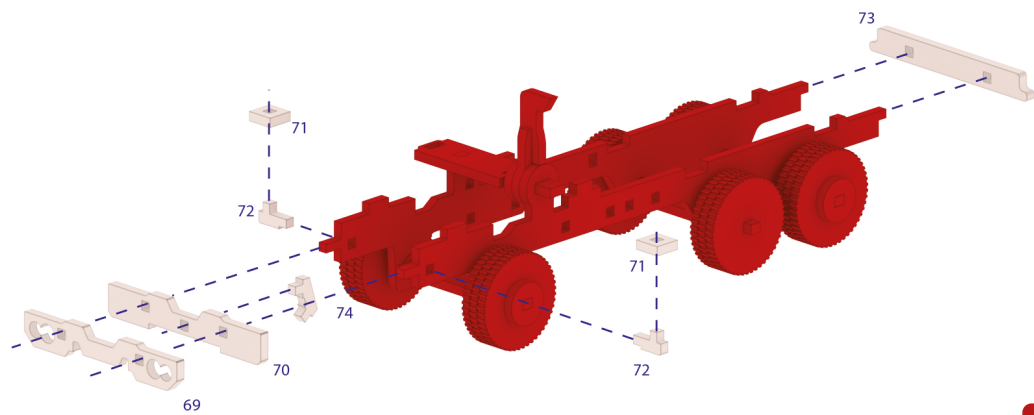
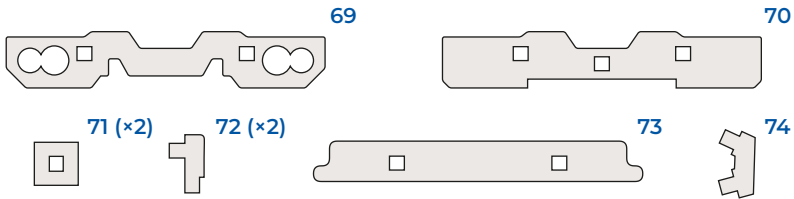

27

1

3

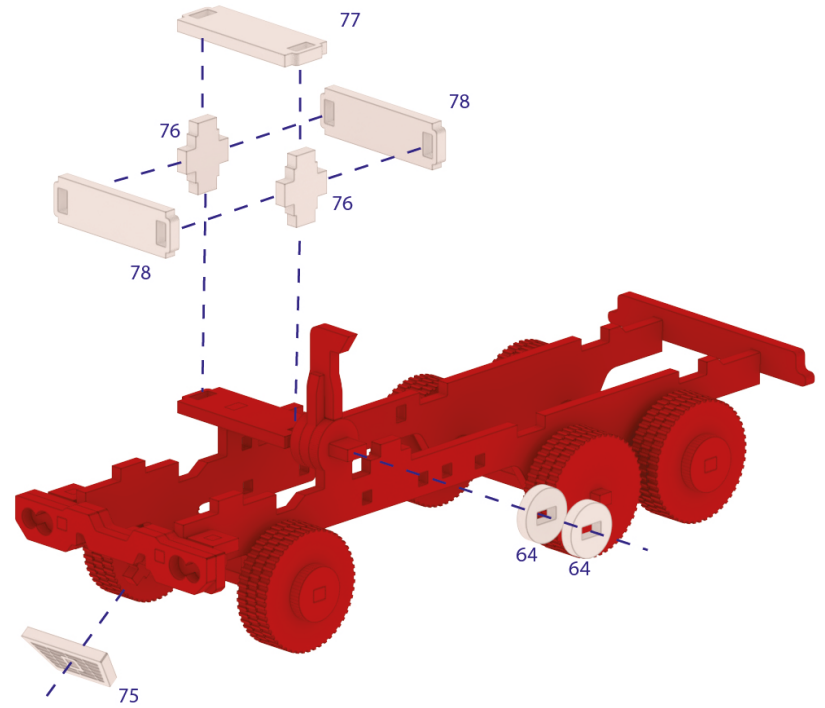
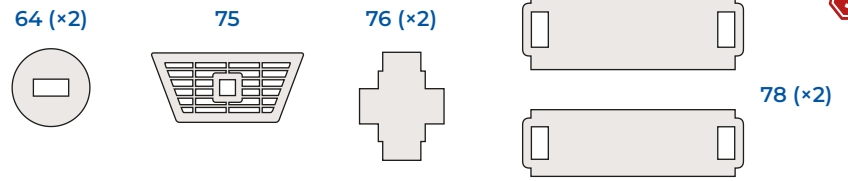

28

3

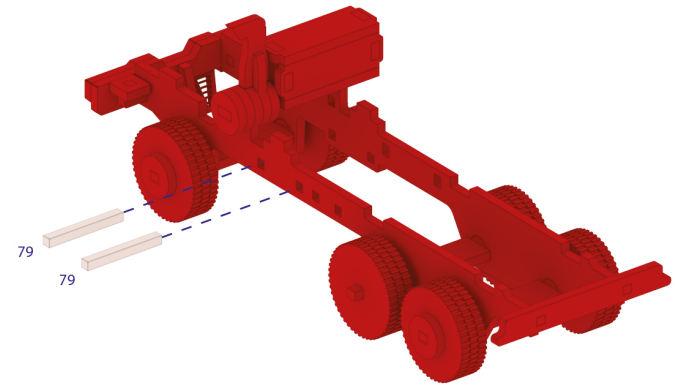
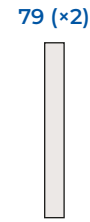

29

80 (x8)

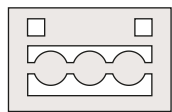

81 (x2)



82



83



2

3

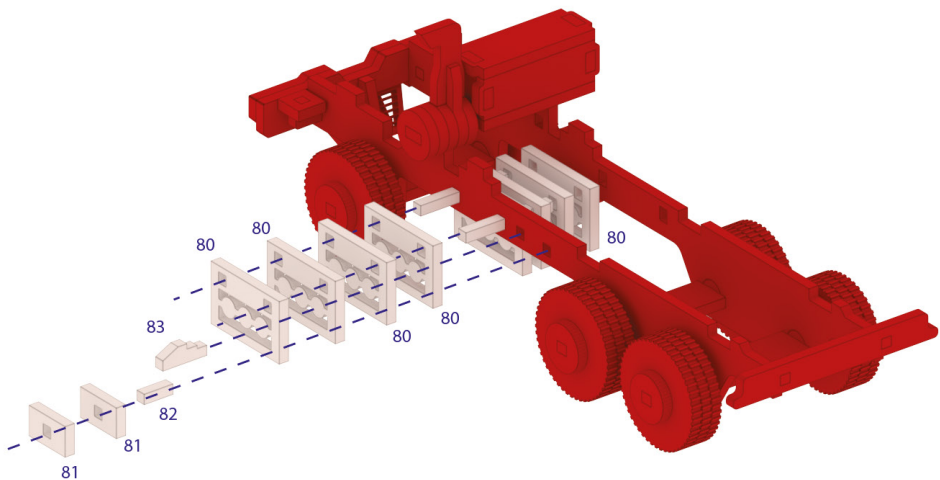

30

84



85 (x2)



86



87 (x6)



3

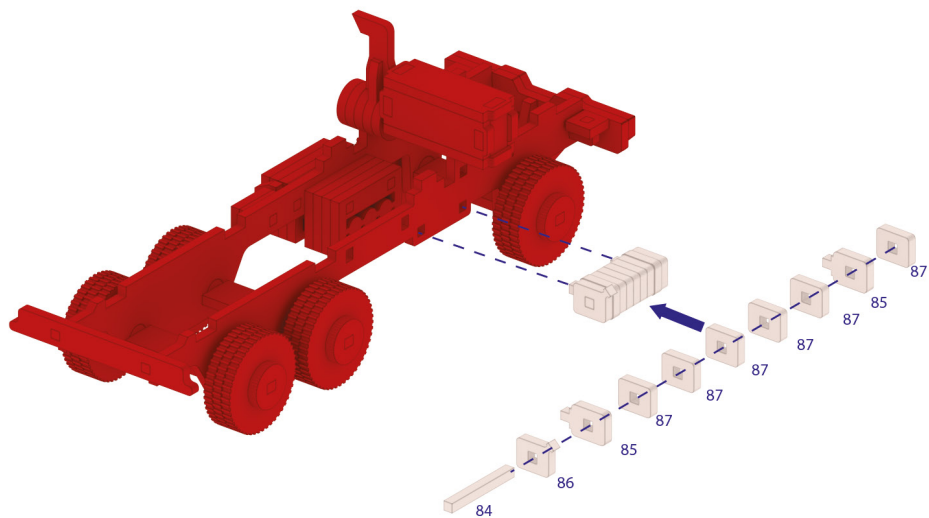

31

88 (x4)



89



3

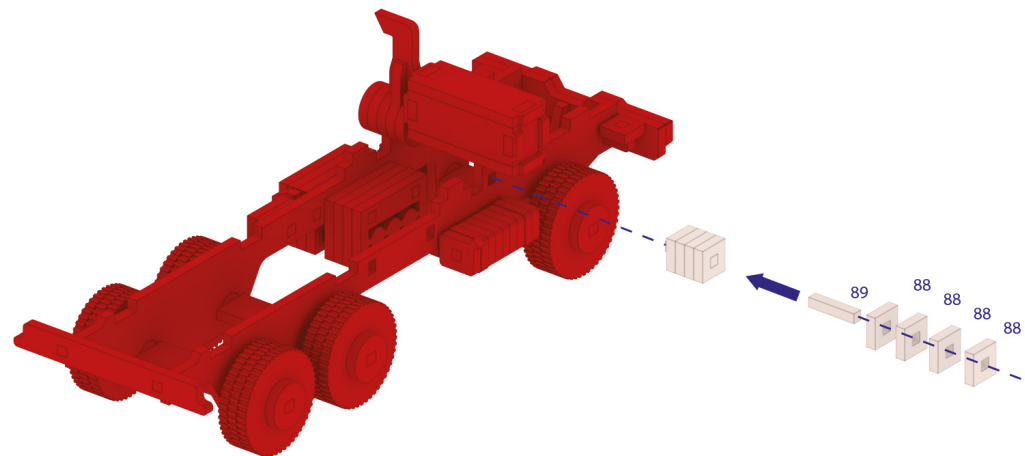

32

84



90 (x2)



91 (x7)



3

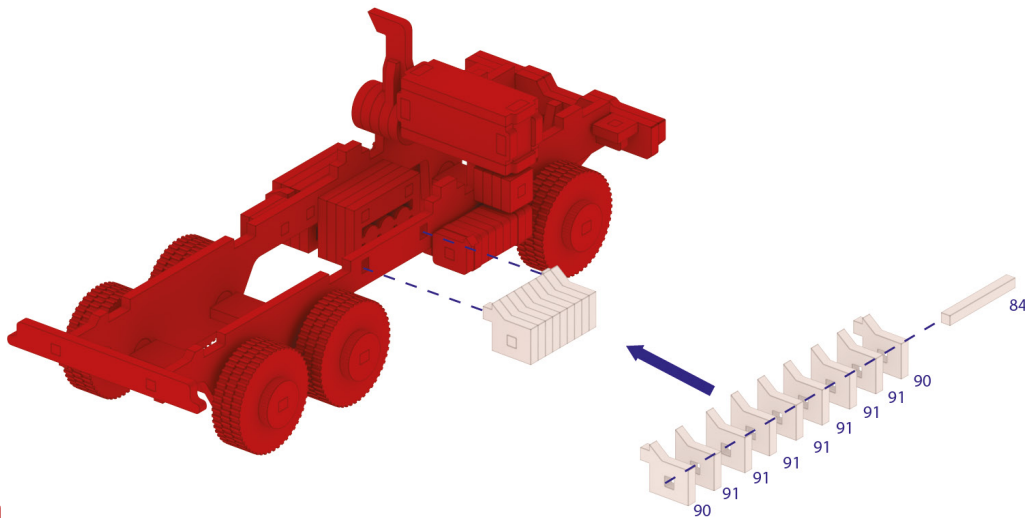

33

3

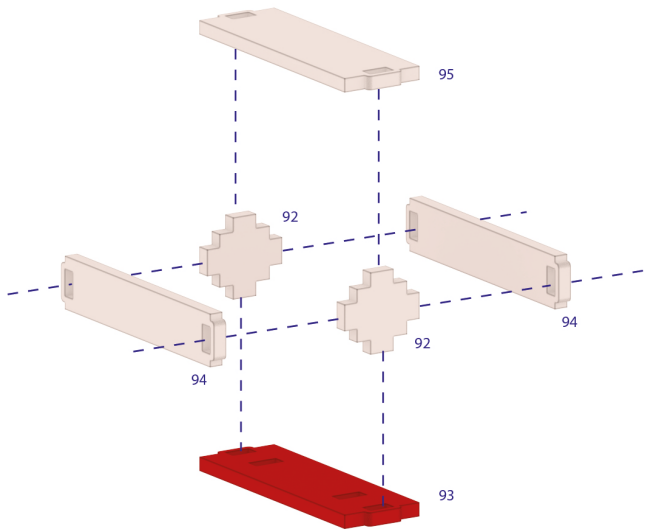
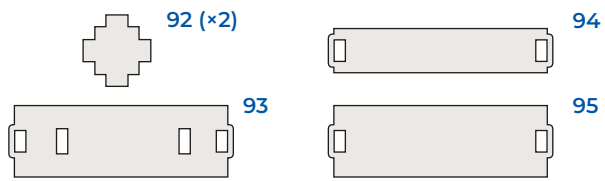

34

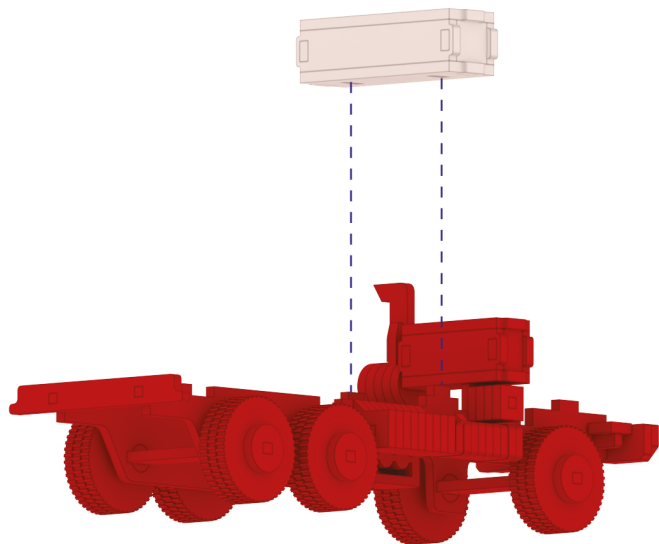

35

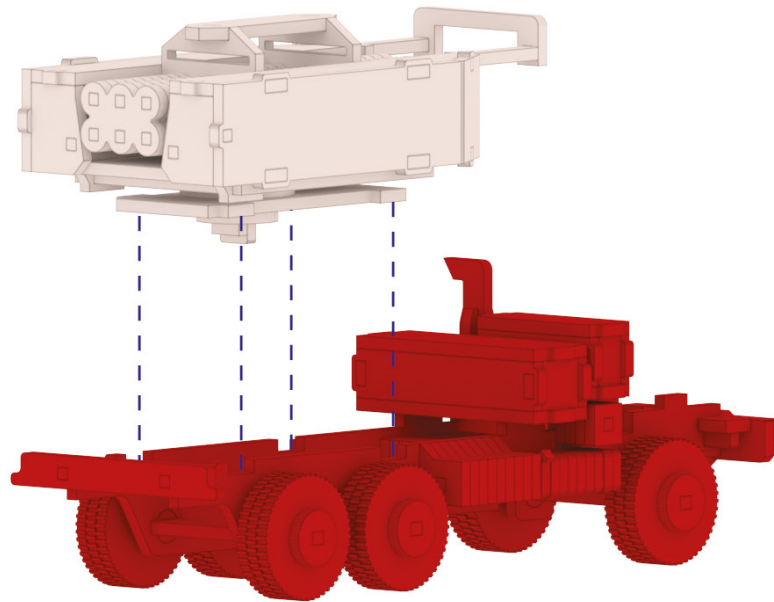

36

