

OFFICIALLY LICENSED BY

UKRAINIAN ARMOR

Design and
Manufacturing
Company



ДЕРЕВ'ЯНИЙ ПАЗЛ **3D**
WOODEN PUZZLE



THE
GRAVIX
3D PUZZLES

ІНСТРУКЦІЯ
INSTRUCTION

Зверніть увагу!

1. Щоб дістати деталі з планшетки використовуйте допоміжний елемент.
2. Деякі елементи пазлу можуть з'єднуватися із зусиллям.
3. Якщо елемент з'єднується із зусиллям або не входить в паз іншої деталі, то потрібно скористатися пилочкою.
4. Якщо деталь при з'єднанні занадто вільно тримається в пазах конструктора, тоді краще додатково використати клей.
5. Запасні деталі позначені номером в дужках.
6. Будьте уважними, та не поспішайте.

Pay attention!

1. Use the auxillary element to get the parts from the tablet.
2. Some parts of the puzzle can be connected with force.
3. If the element is connected with difficulty or does not fit into the groove of another part, then you need to use the nail file.
4. If the part is too loose when connected, does not hold in the grooves of the constructor, then it is better to additionally use glue
5. If you see parts marked with a number in parentheses, they are spare.
6. Be careful and take your time.

7 — Номер планшетки з необхідними деталями.
Tablet number with the necessary parts.

1

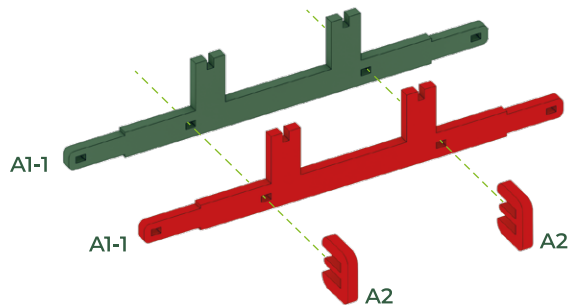
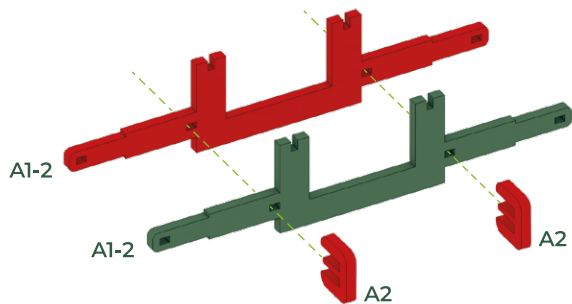
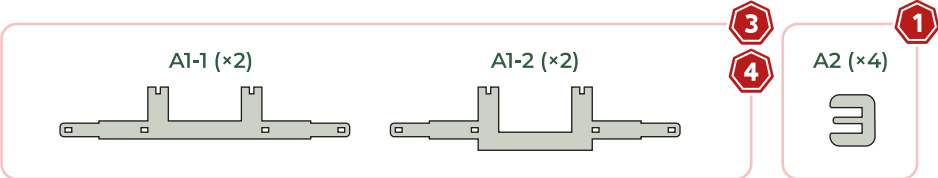

2

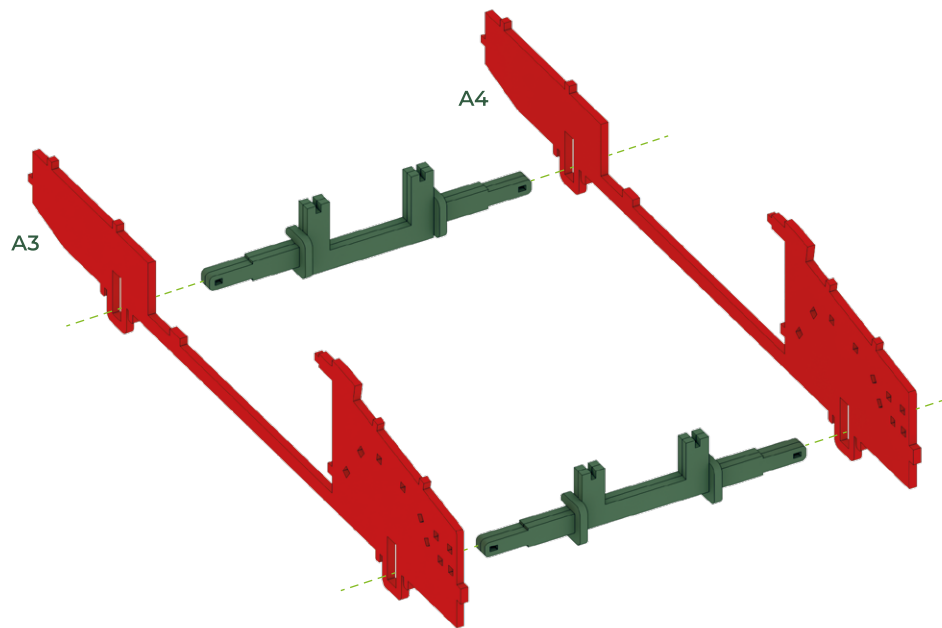
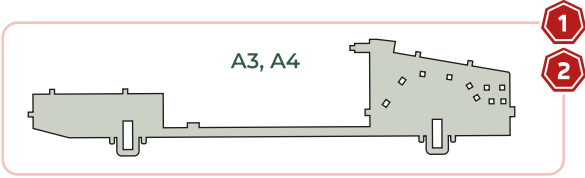

3

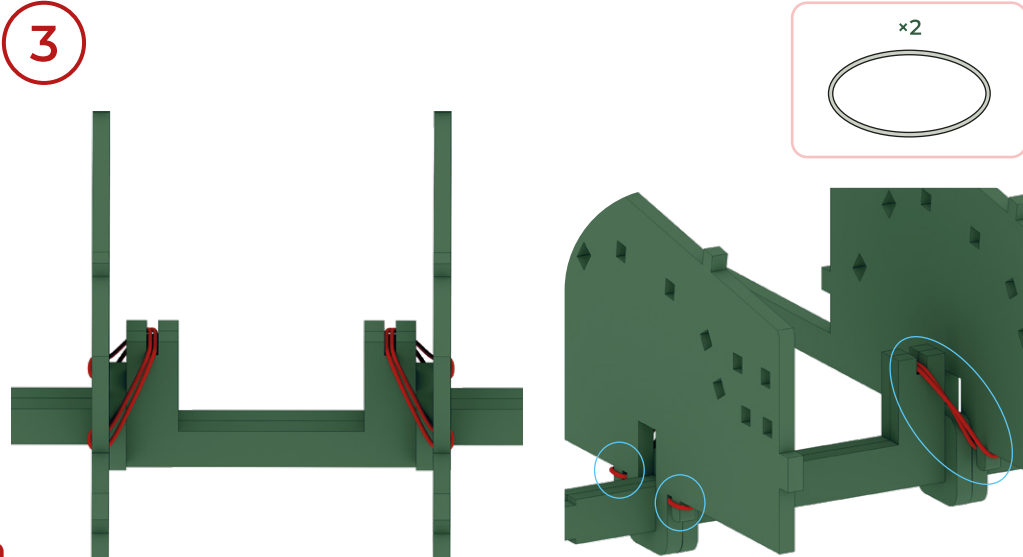

4

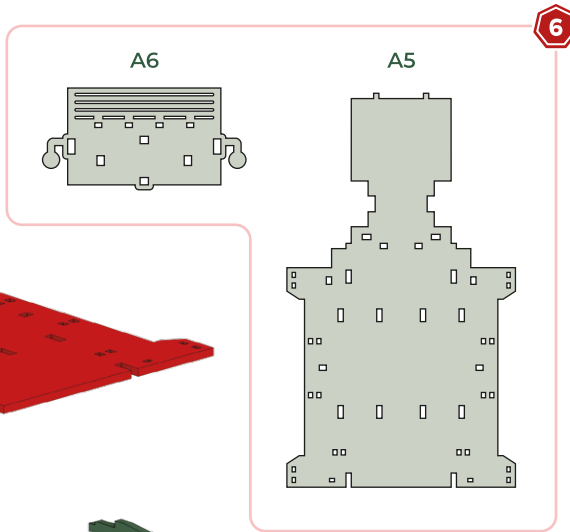
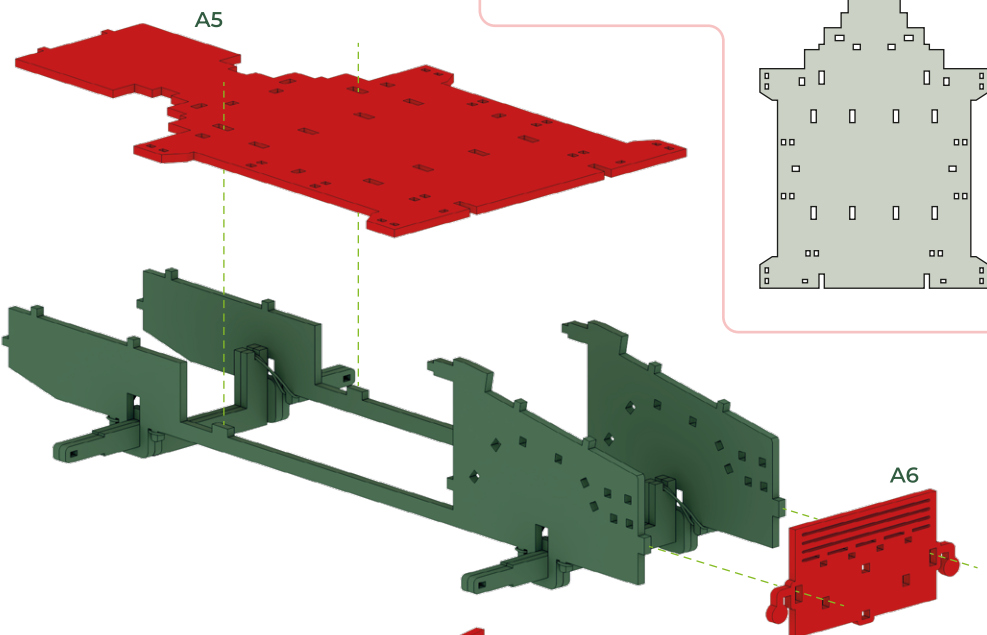

5

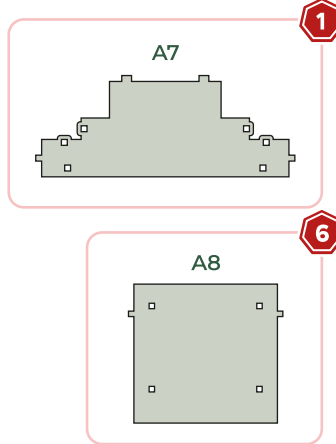
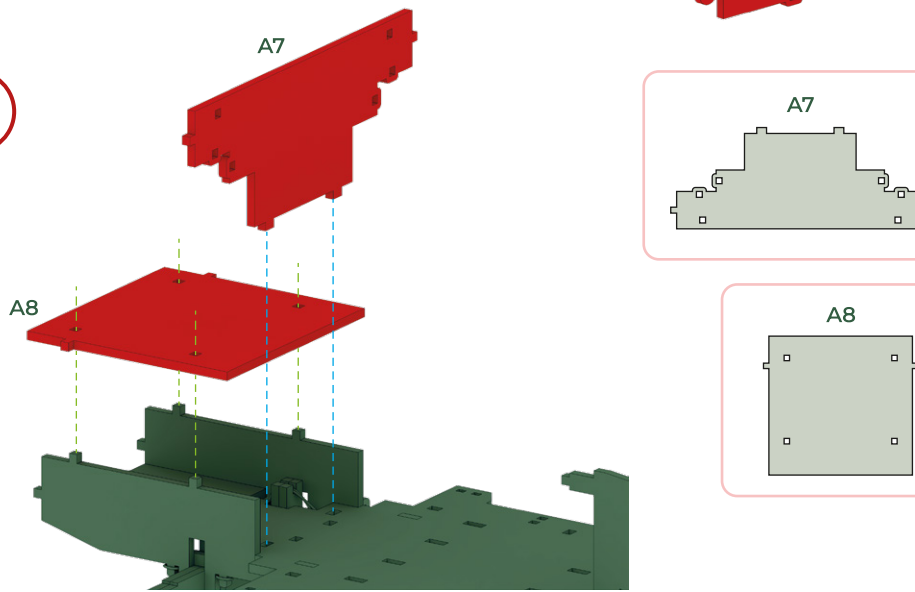

6

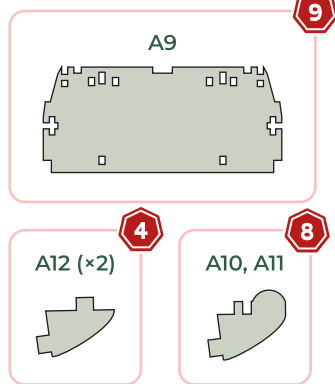

7

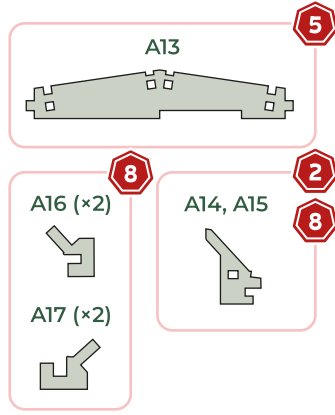

8

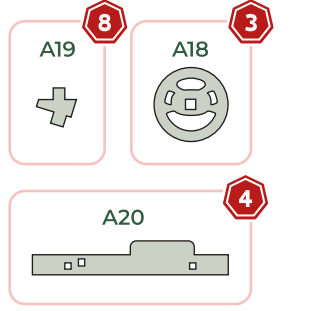

9

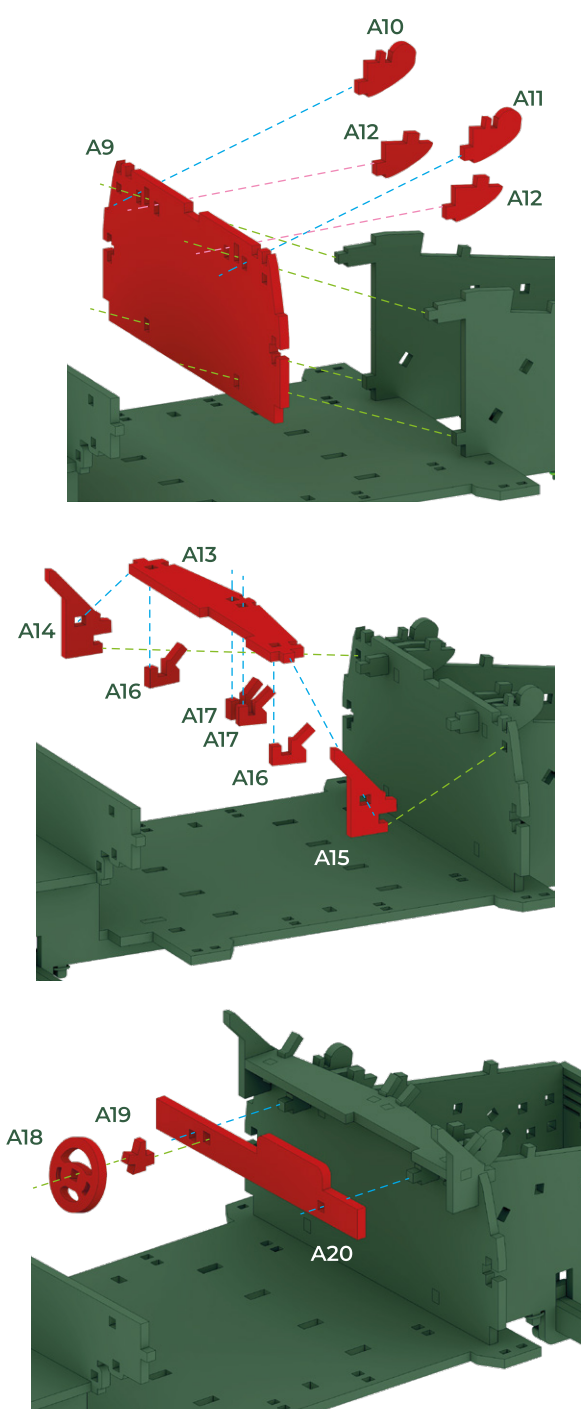

9

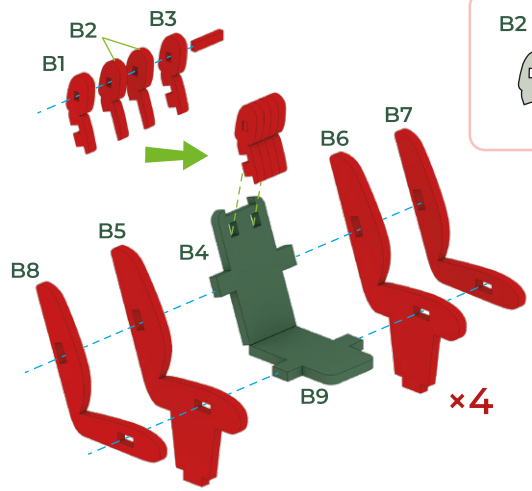

5
9

B2 (x8)

9

1 (x4) (B1, B3) x4

(B5, B6) x4 (B7, B8) x4

5

2-5

B4 (x4) B9 (x4)

10

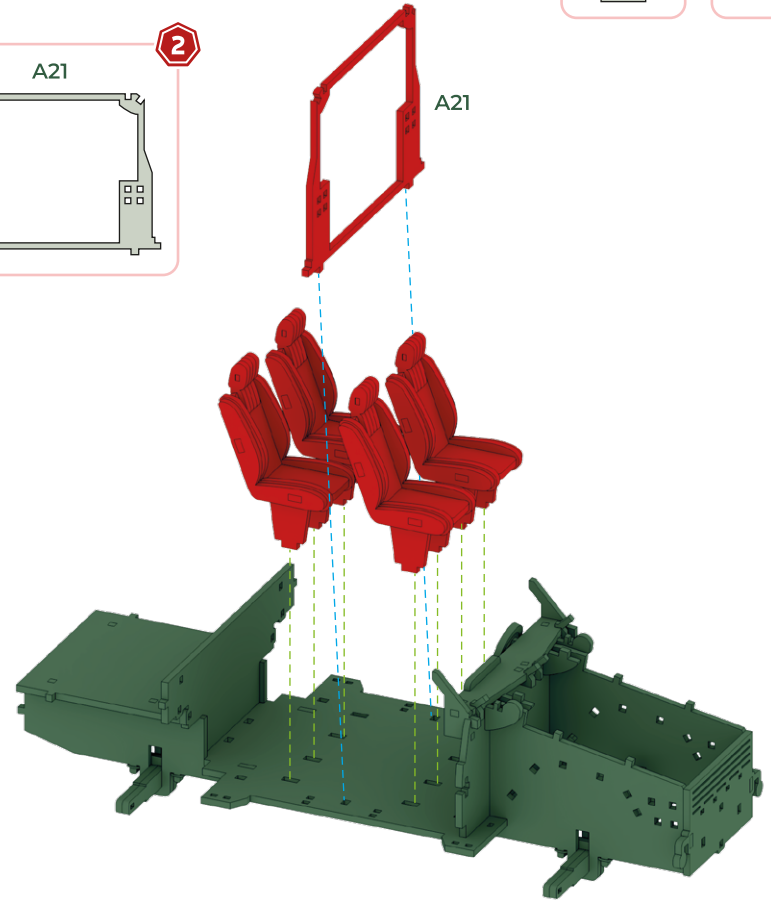
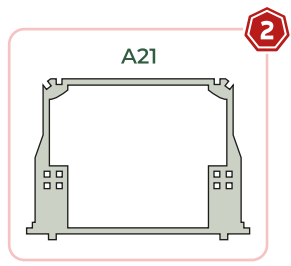

11

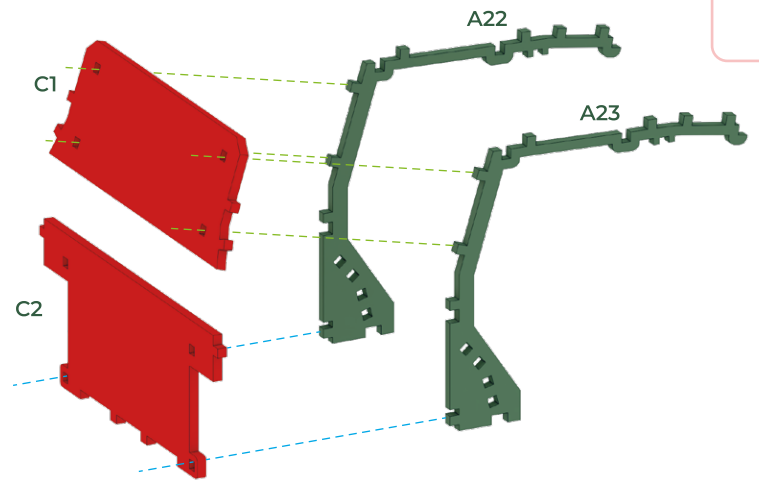
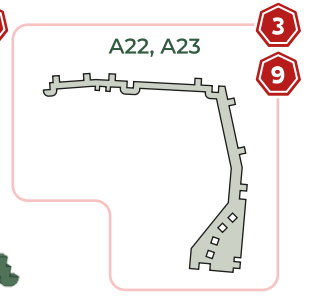
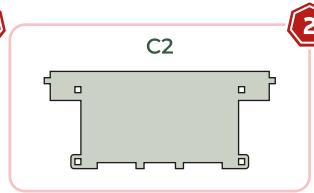
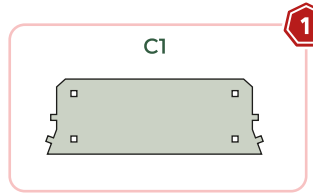

12

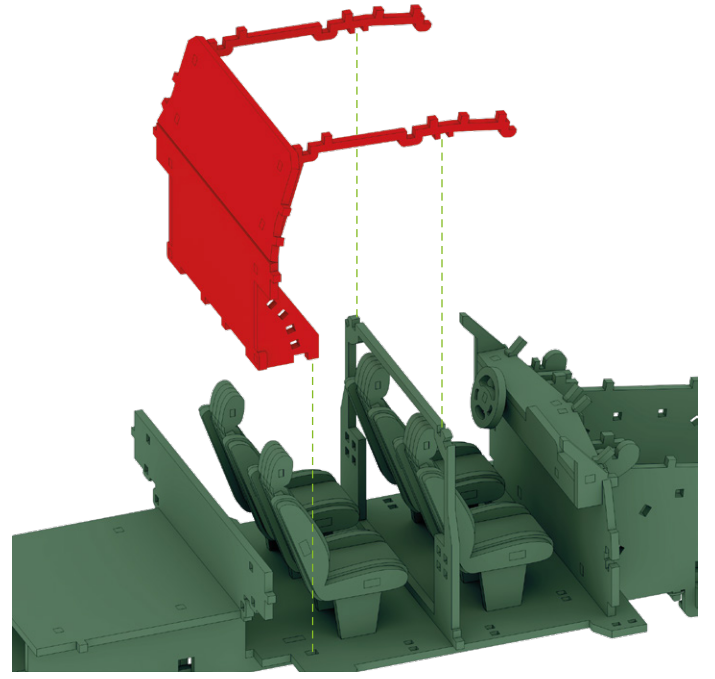

13

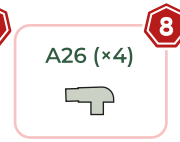
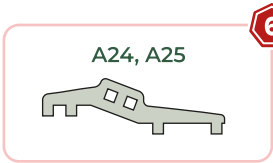
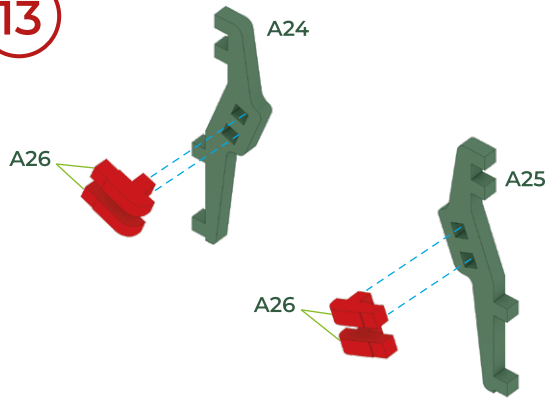

15

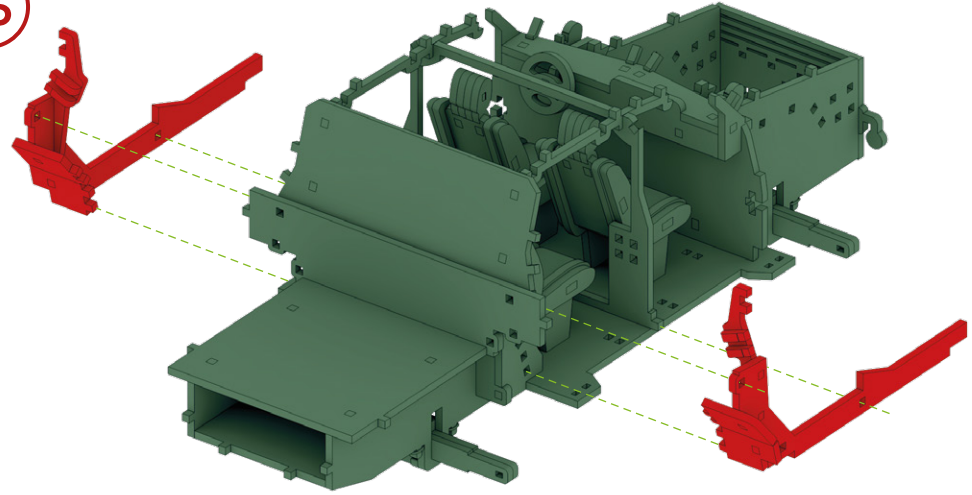

14

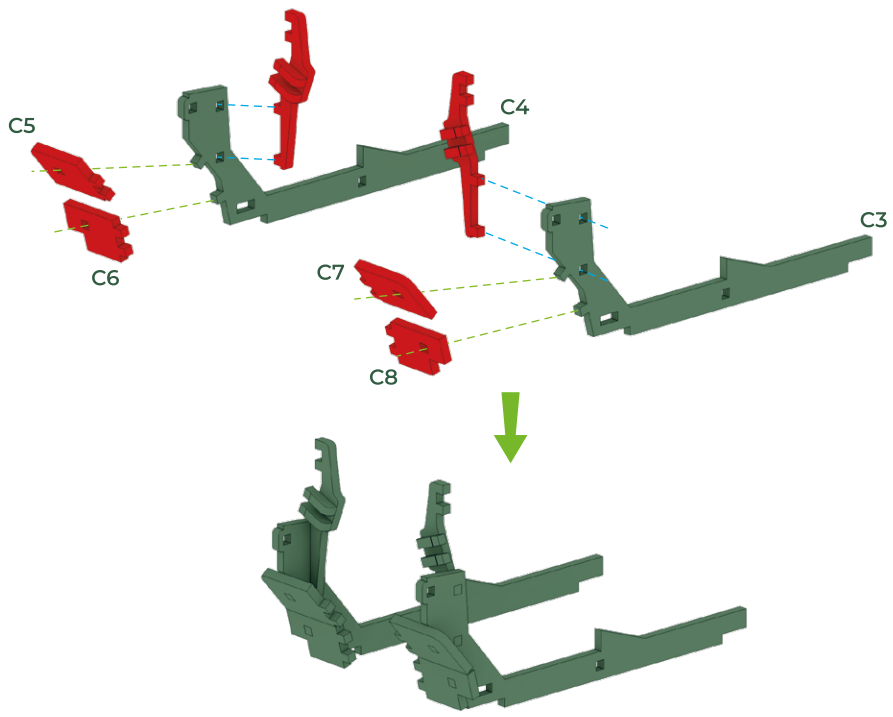
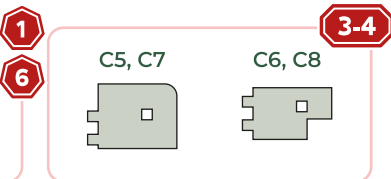
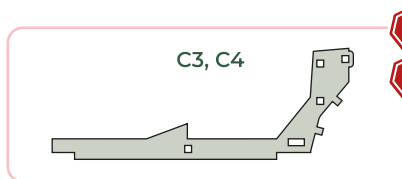

16

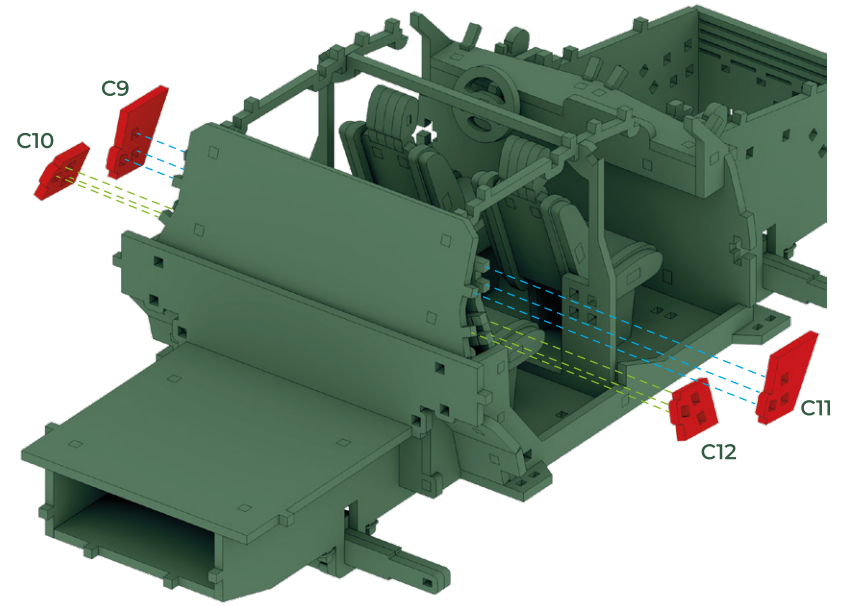
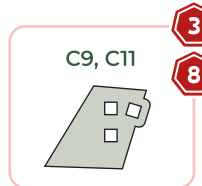

17

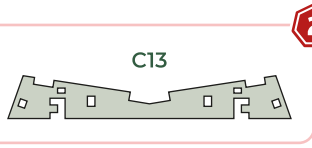

2

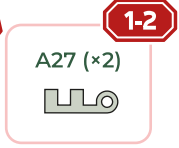

1-2

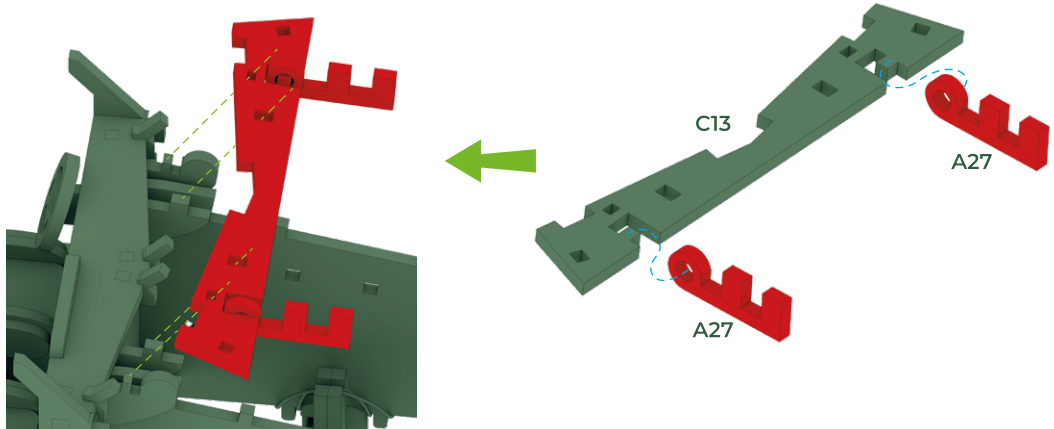

18

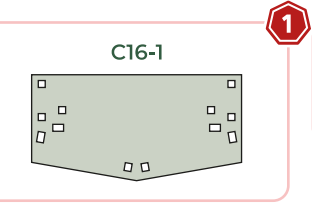

1

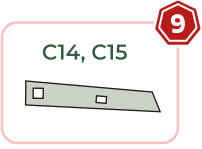

9

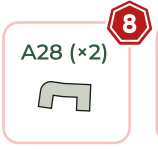

8

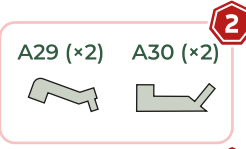

2

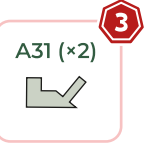

3

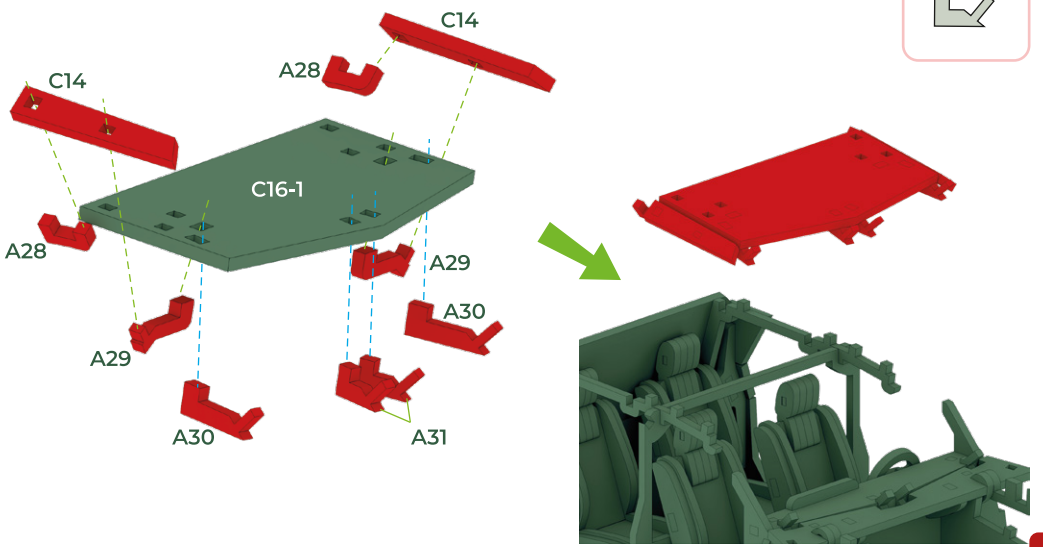

19

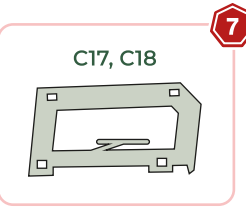
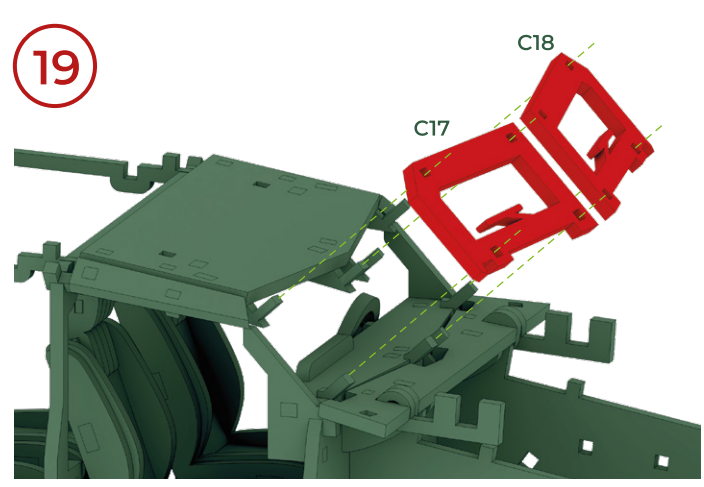

7

20

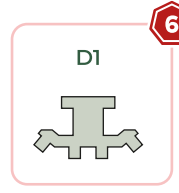

6

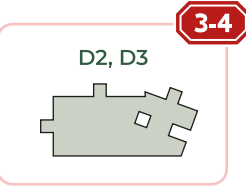

3-4

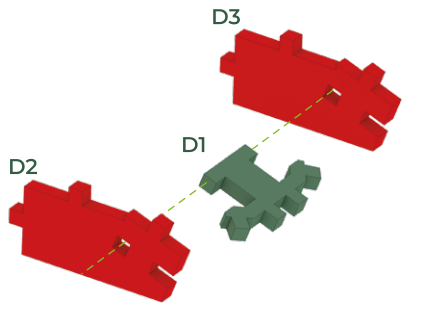

21

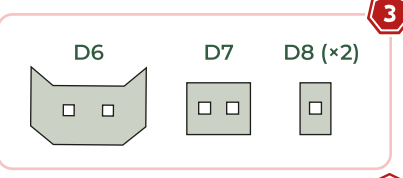
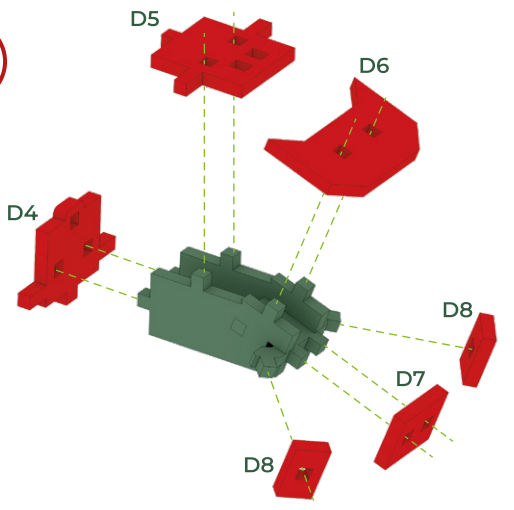

3

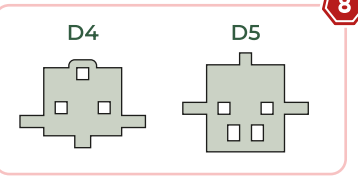

8

22

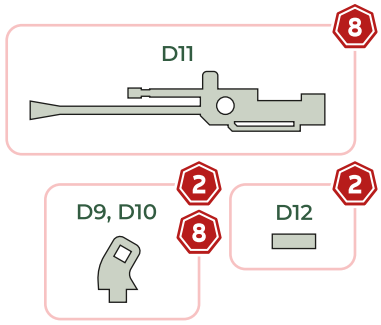
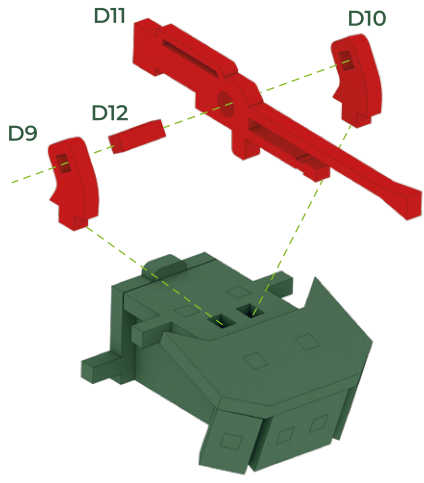

23

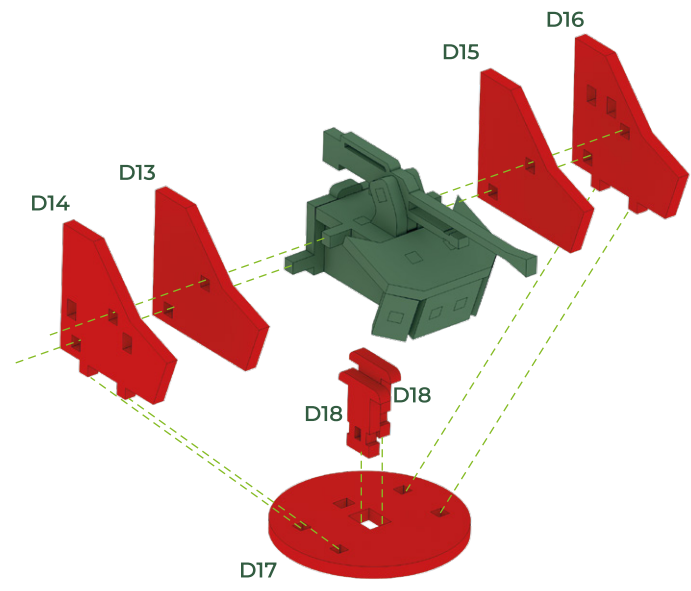
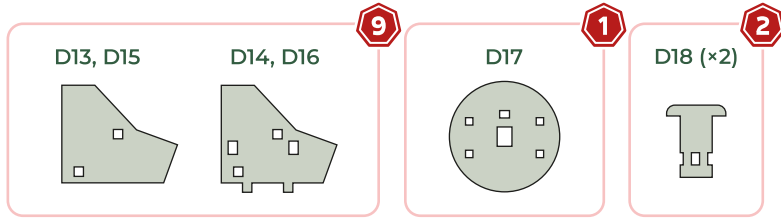

24

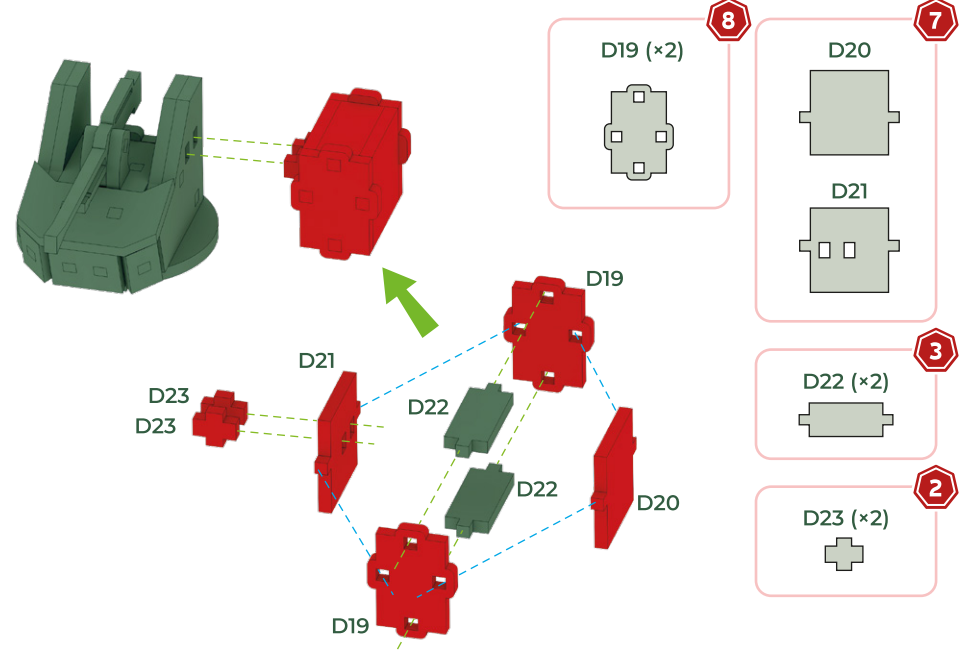

26

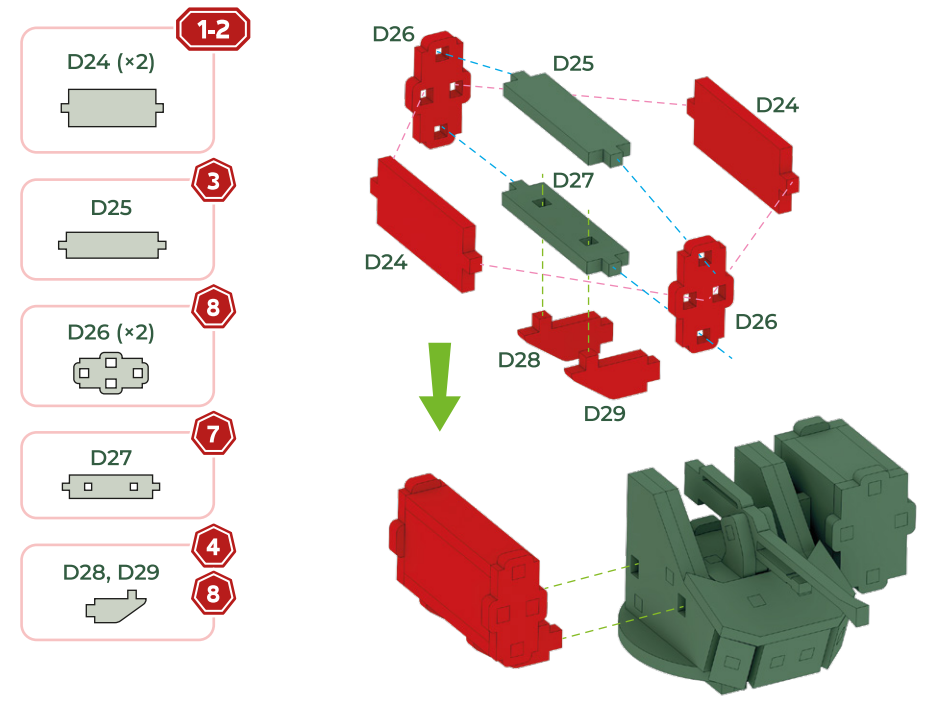

27

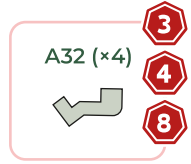
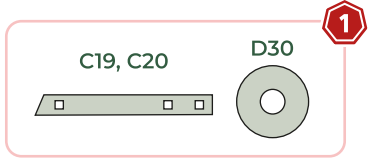
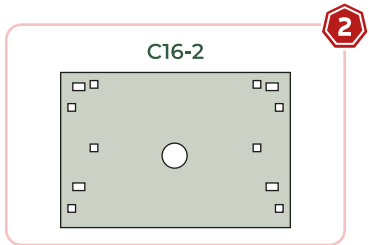
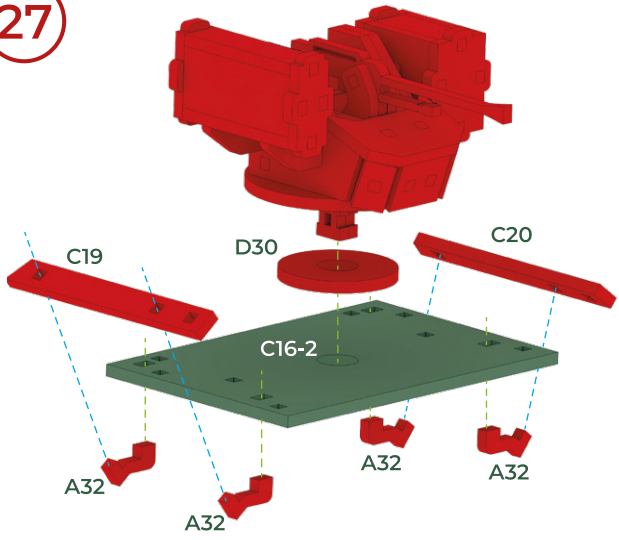

29

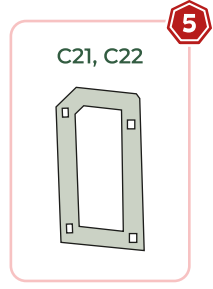
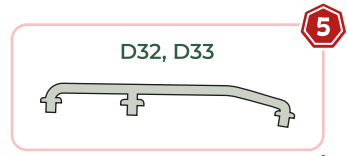
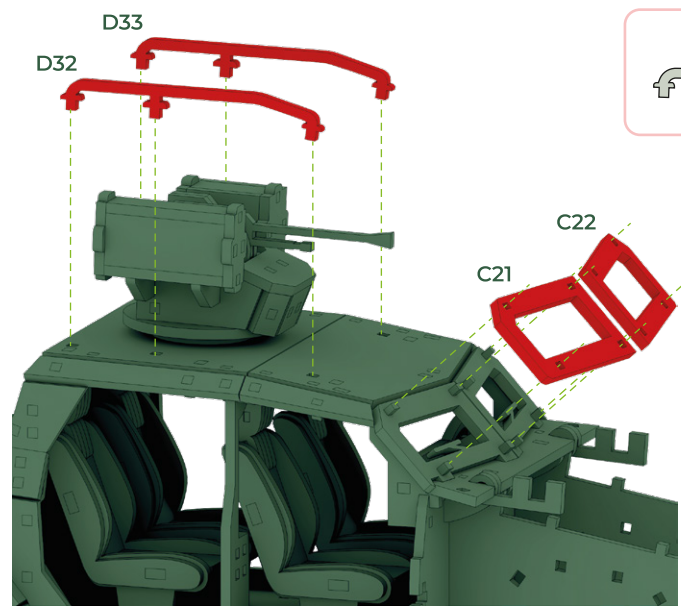

28

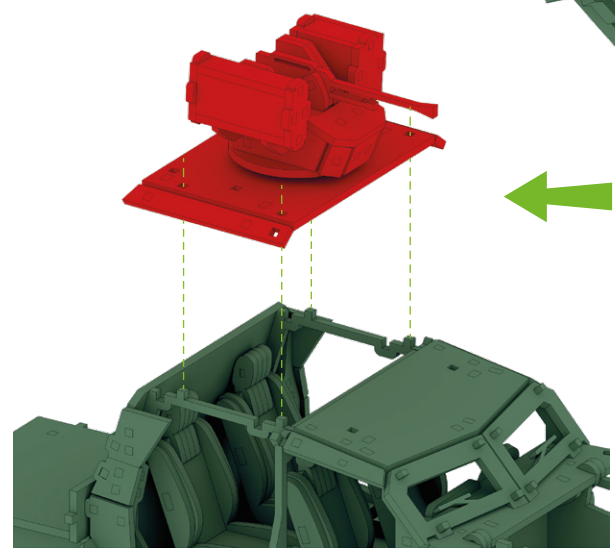
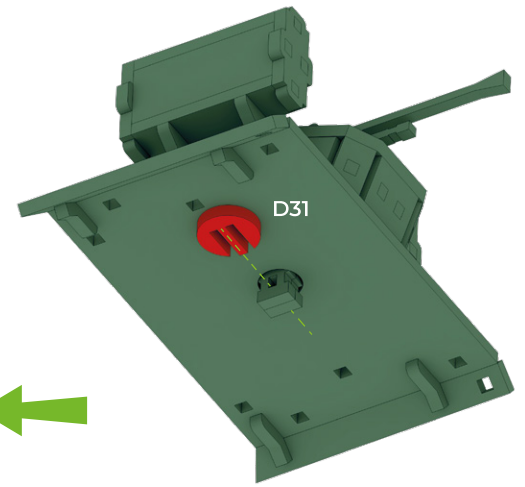

30

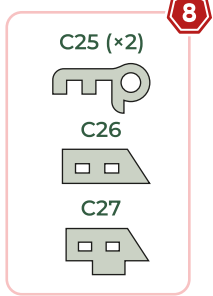
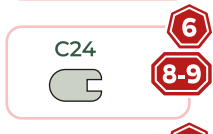
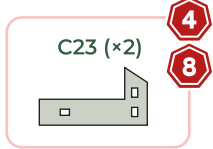
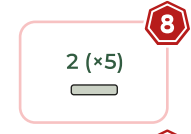
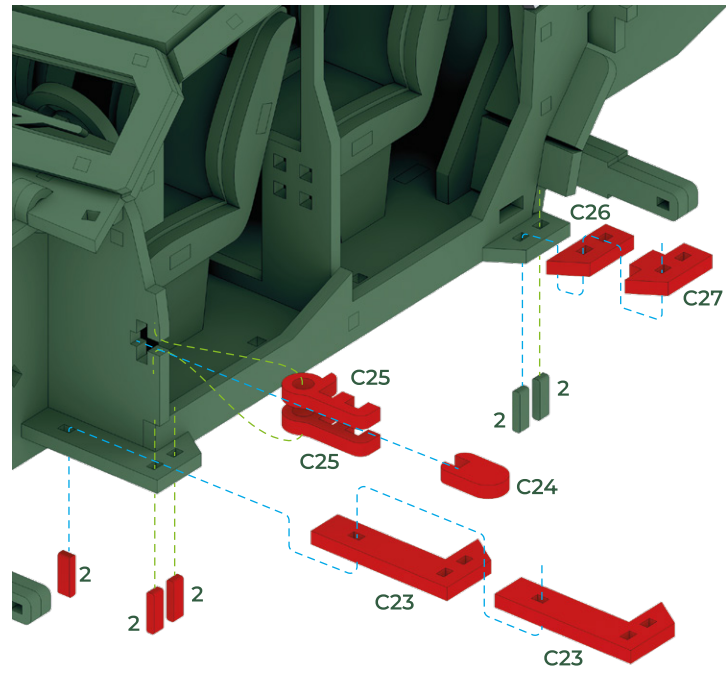

31

- 2 (x5) 8
- C30 (x2) 2
- C24 6 8 9
- C31 (x2) 8
- C29 8
- C28 7

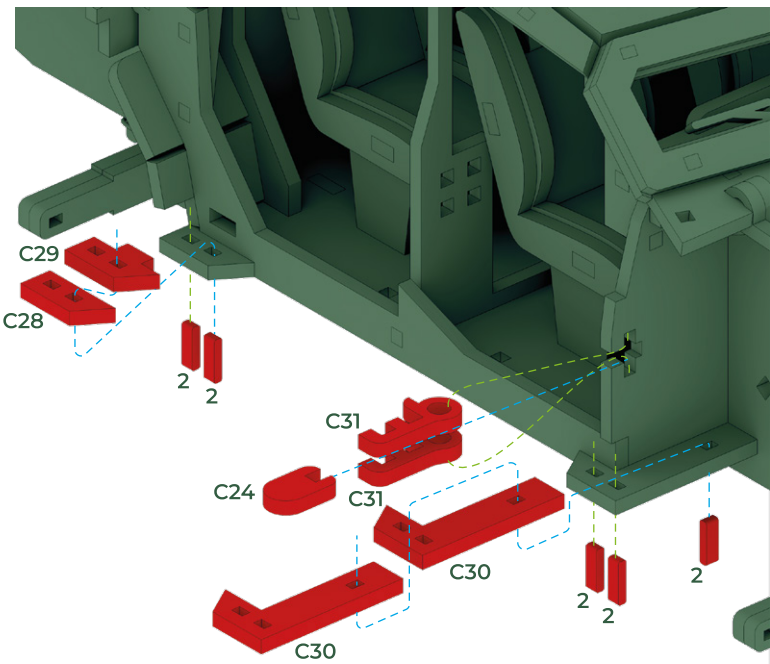

32

- C32, C33 6-7
- C36, C38 8 9
- C34, C37 6 9
- C35, C39 6 9

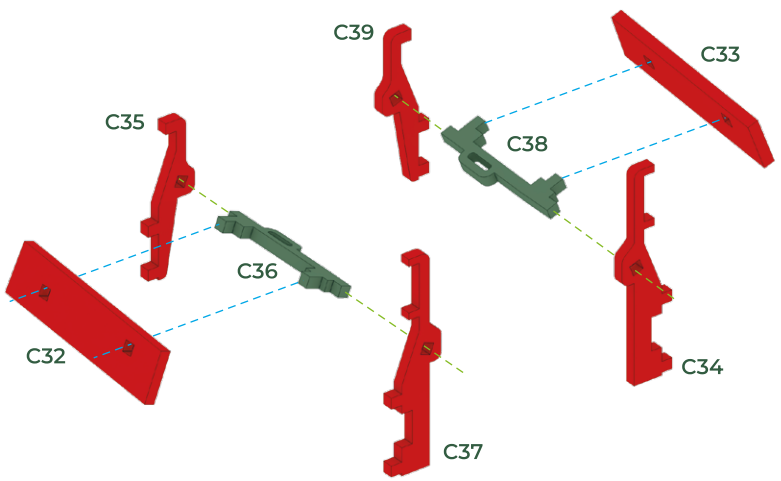

33

- C43, C47 5
- C41, C45 6
- C42, C46 1 6
- (C44, C48) x2 8
- C24 (x2) 6 8-9
- C40 (x2) 5 7 9
- 3 (x4) 1-2 4 6-7 9

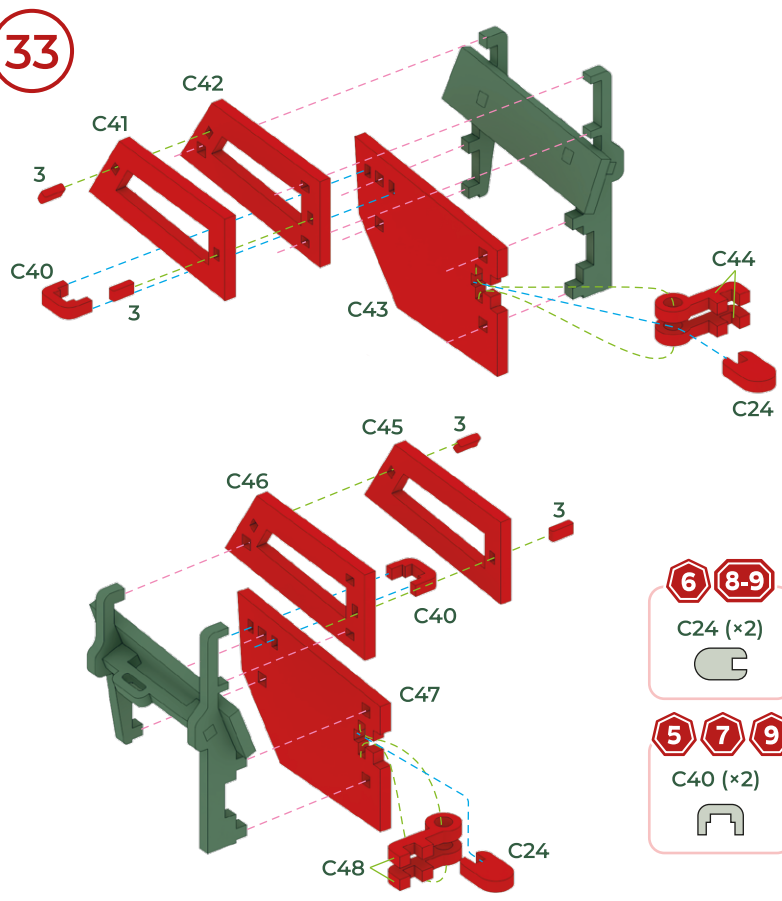

34

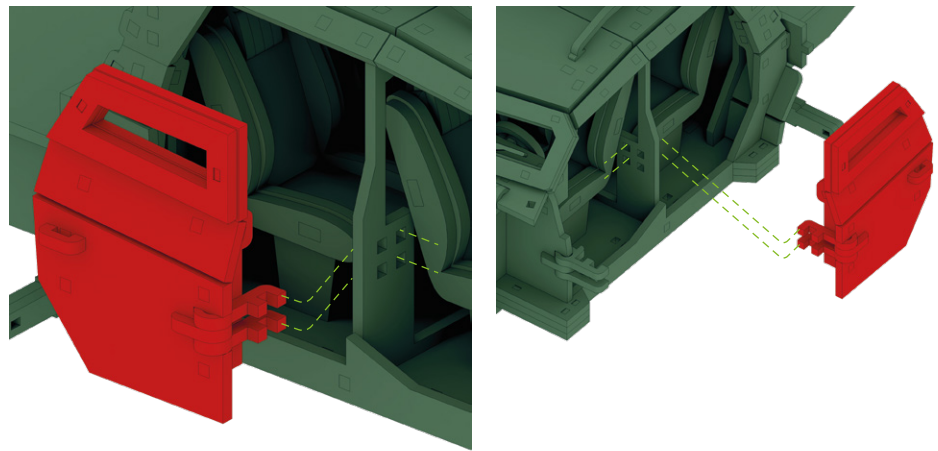

35

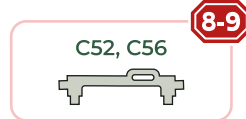
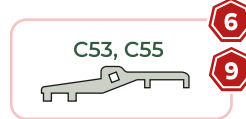
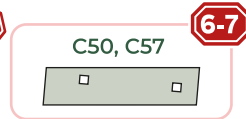
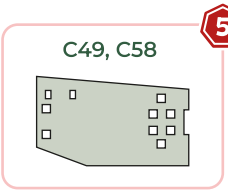
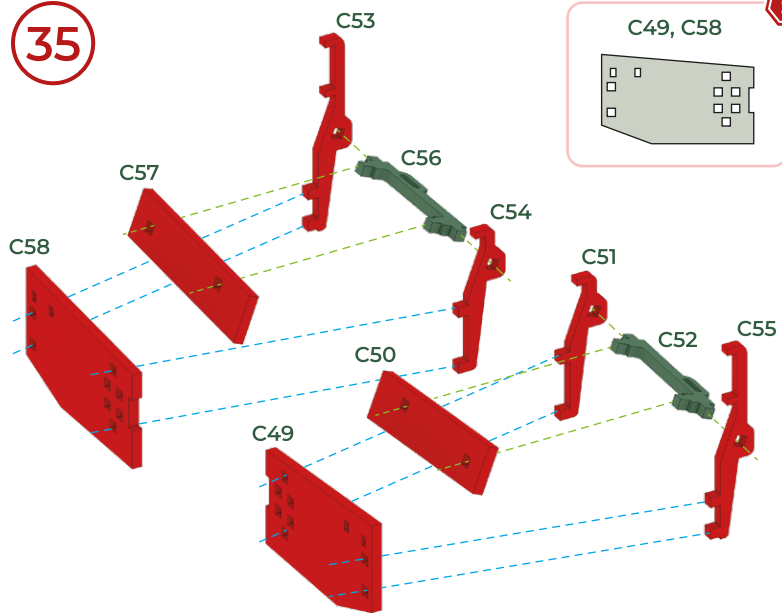

36

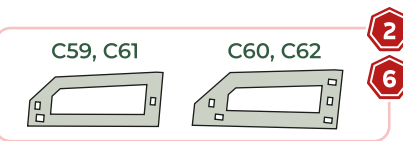
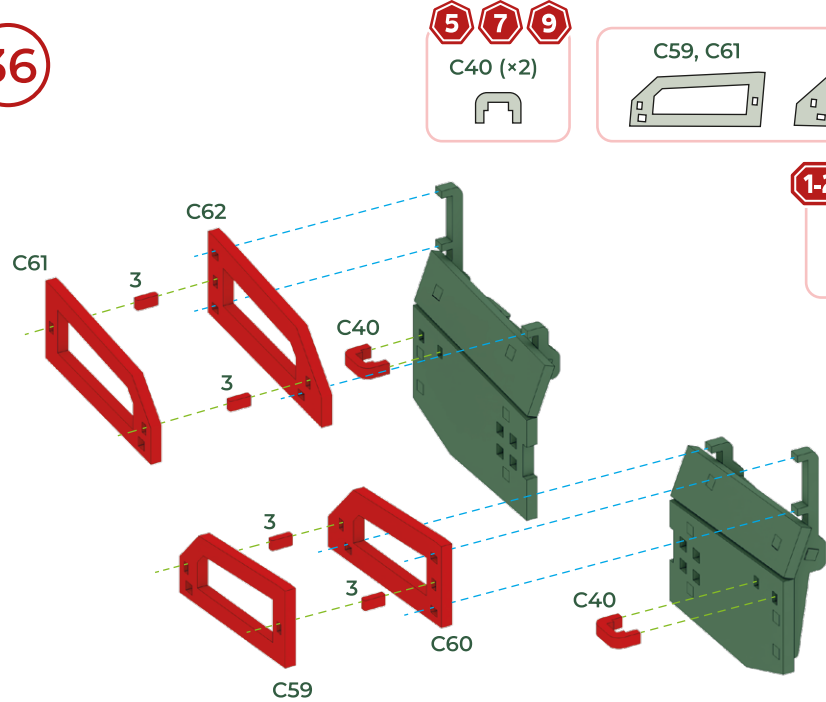

37

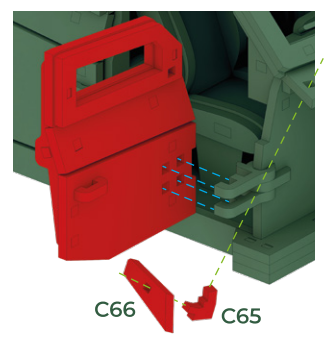
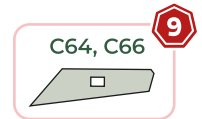
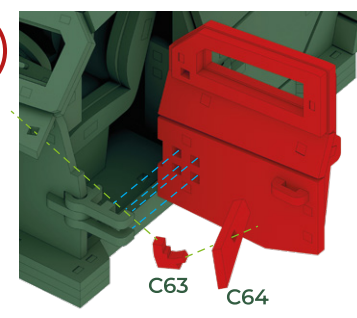

38

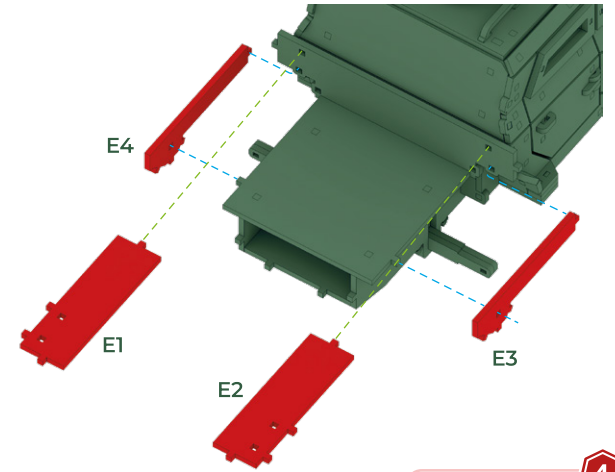
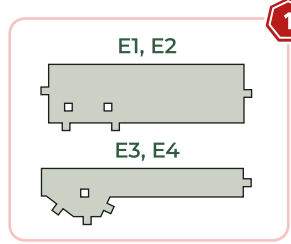

39

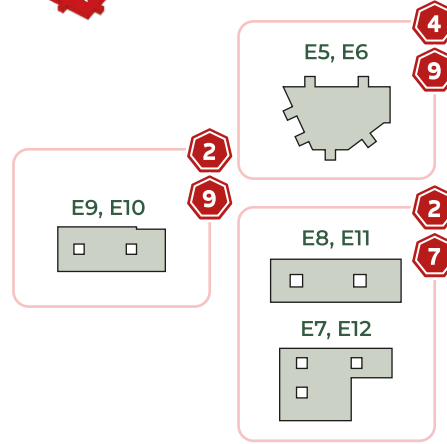
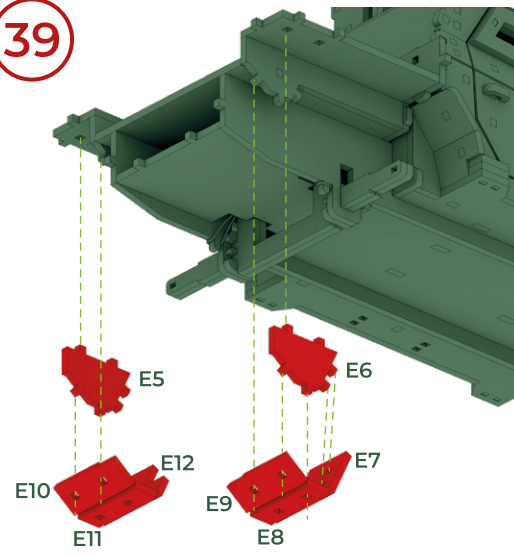

40

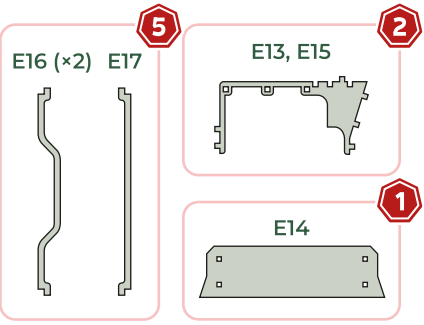
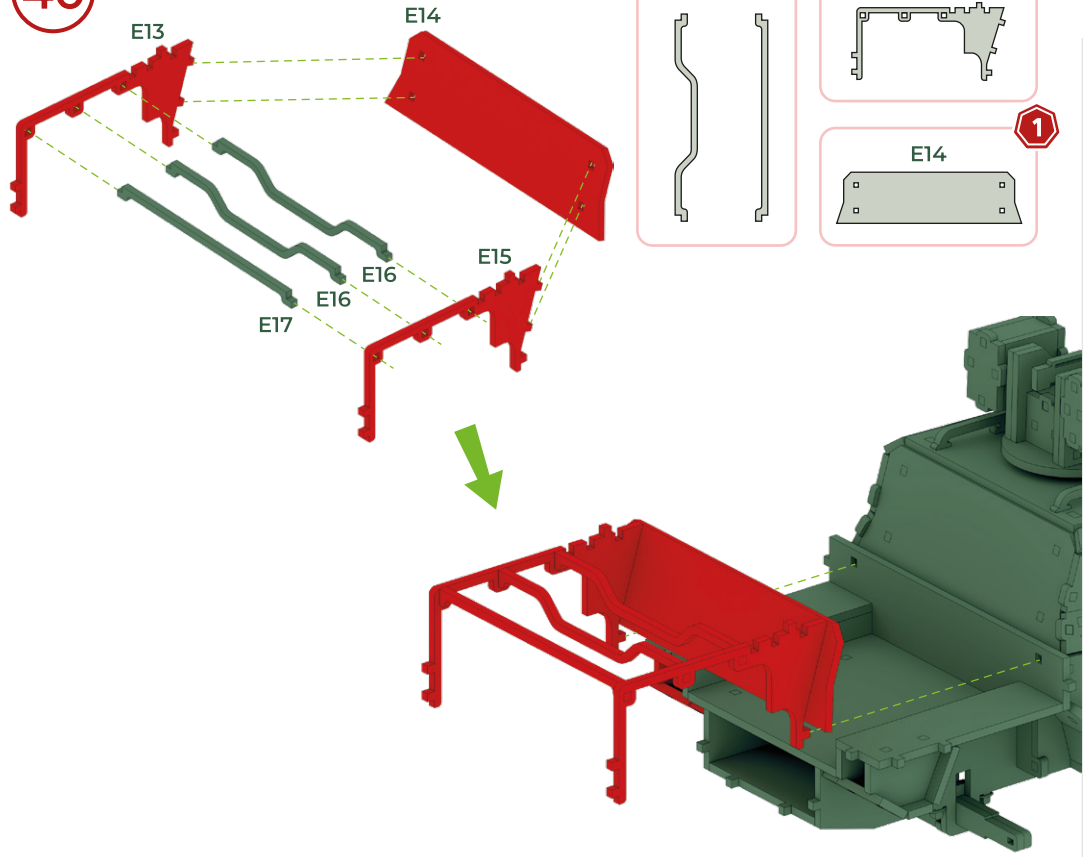

41

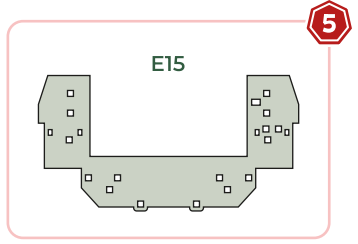
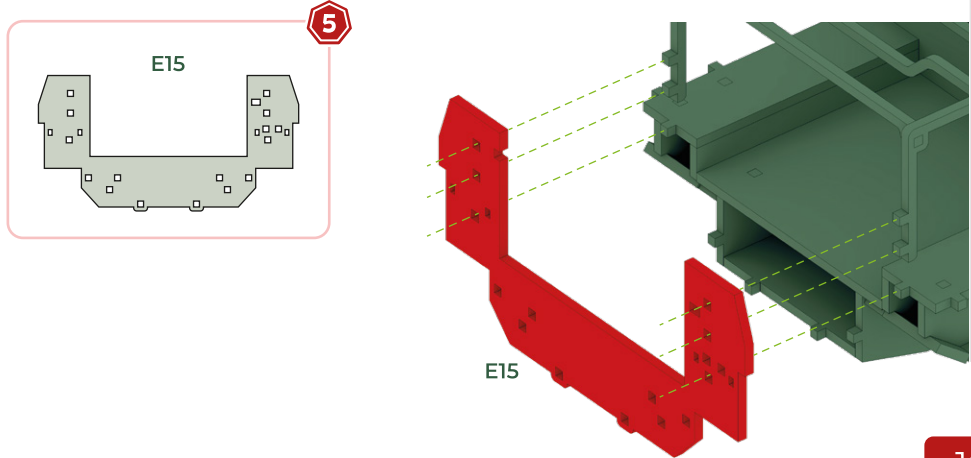

42

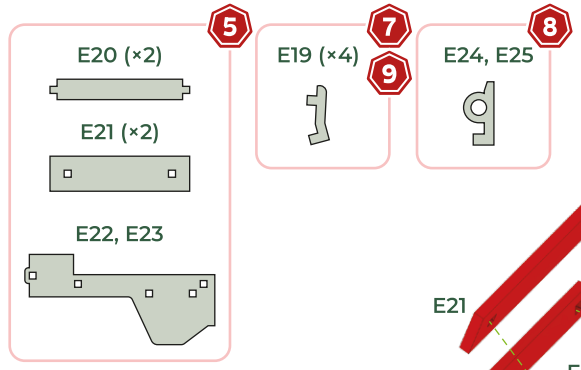
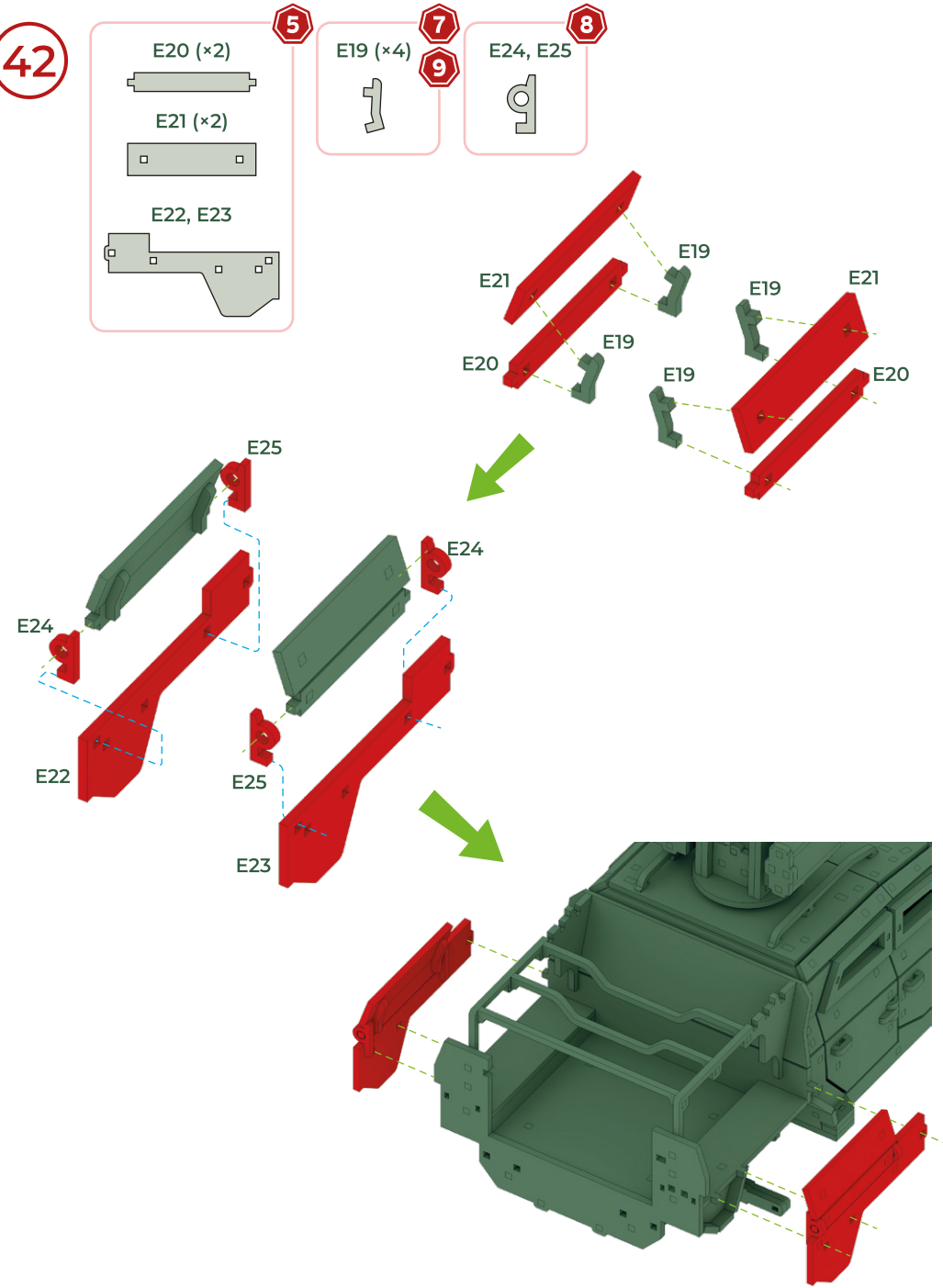

45

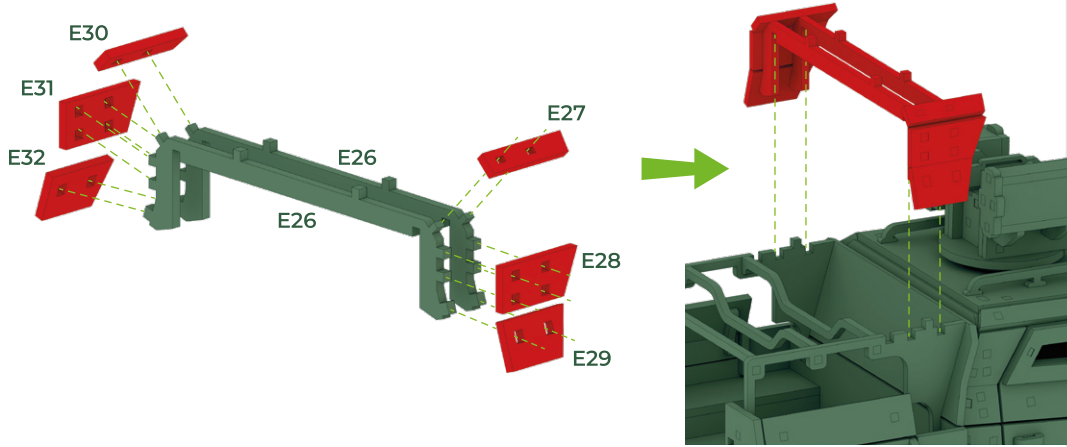

5

3

47

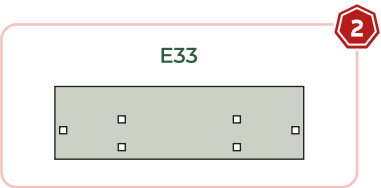
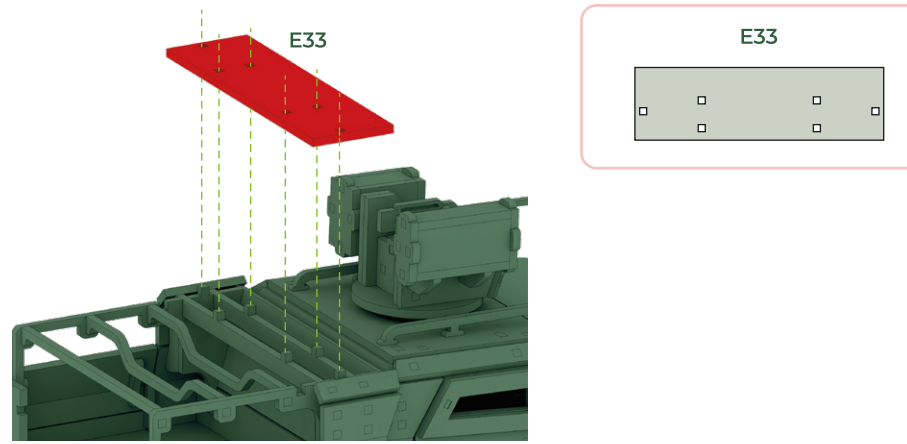

2

46

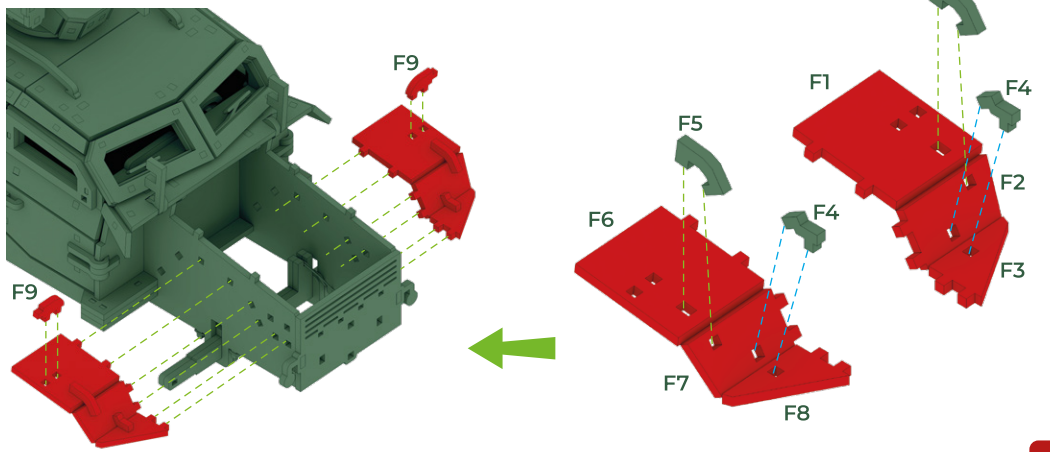
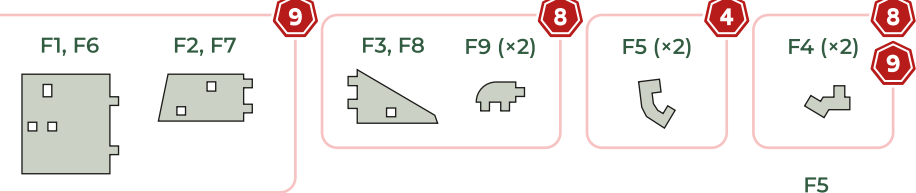

9

8

4

8

9

48

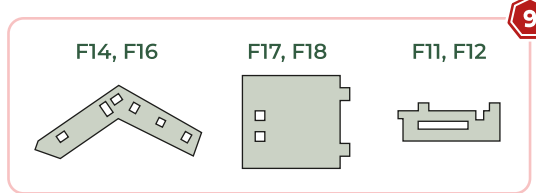
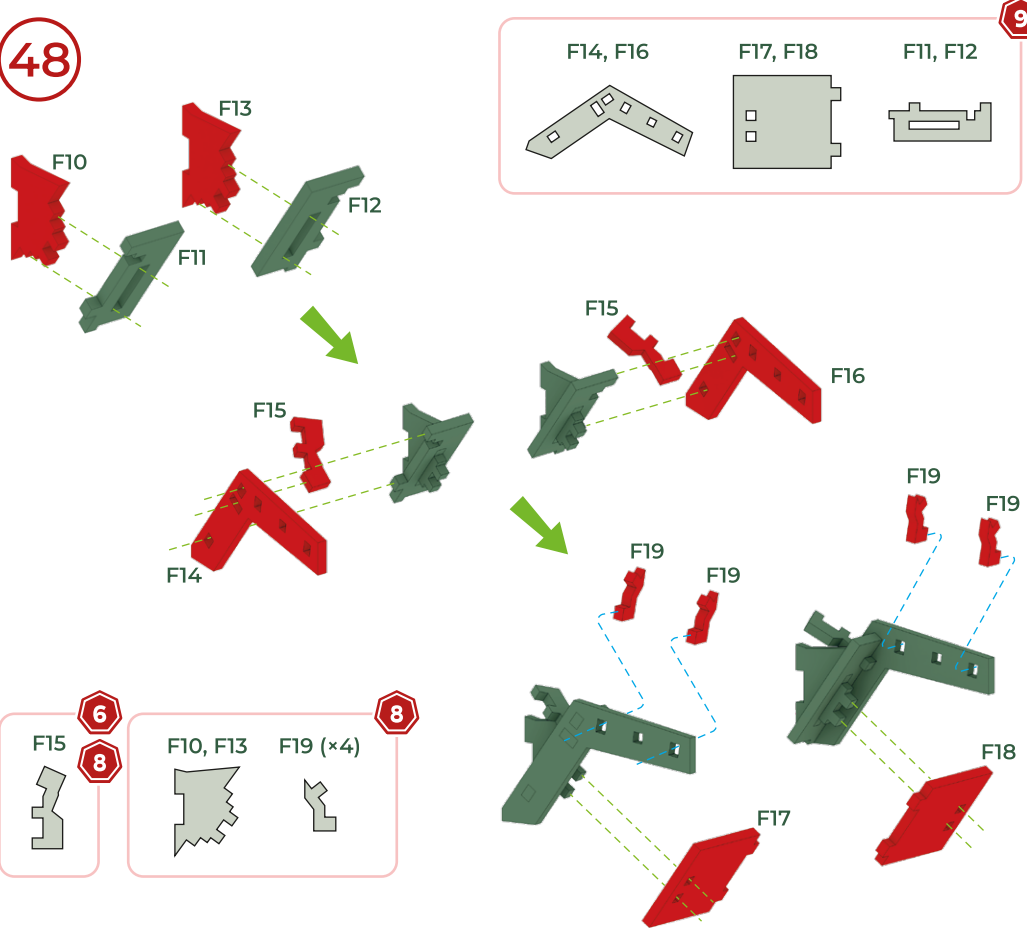

9

6

8

8

49

9

F21, F23

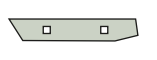

2
7

F20, F22

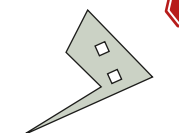
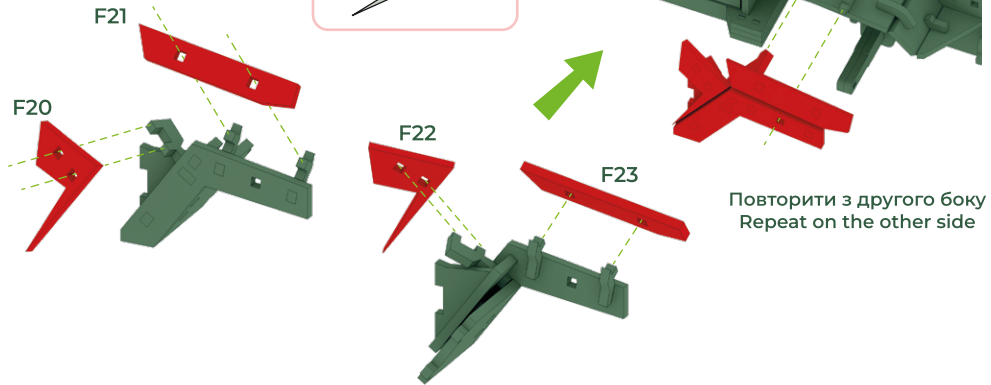

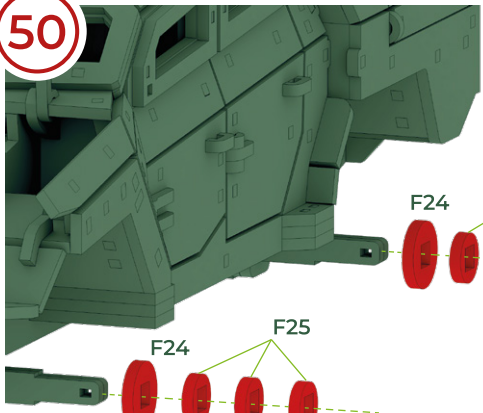

50

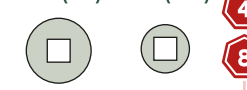

3
4
8

F24 (x4) F25 (x12)



51

2-4 **6-7**

F59 (x16)



Повторити з другого боку
Repeat on the other side

3-4
8

F26 (x12) F27 (x4)

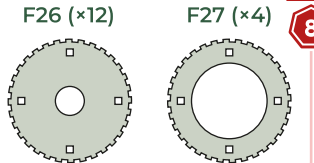
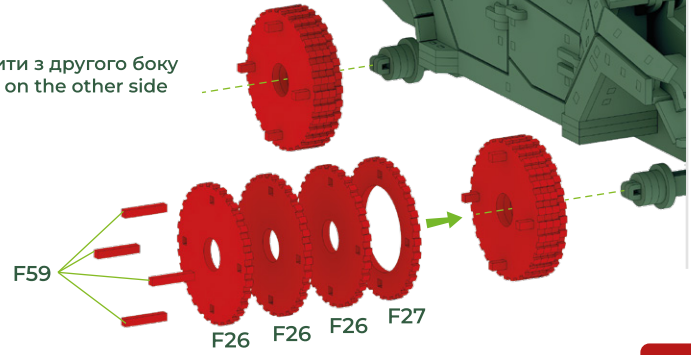
52

3-4

D31 (x4)



Повторити з другого боку
Repeat on the other side

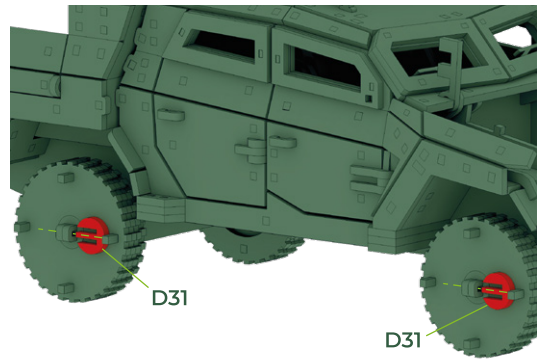

53

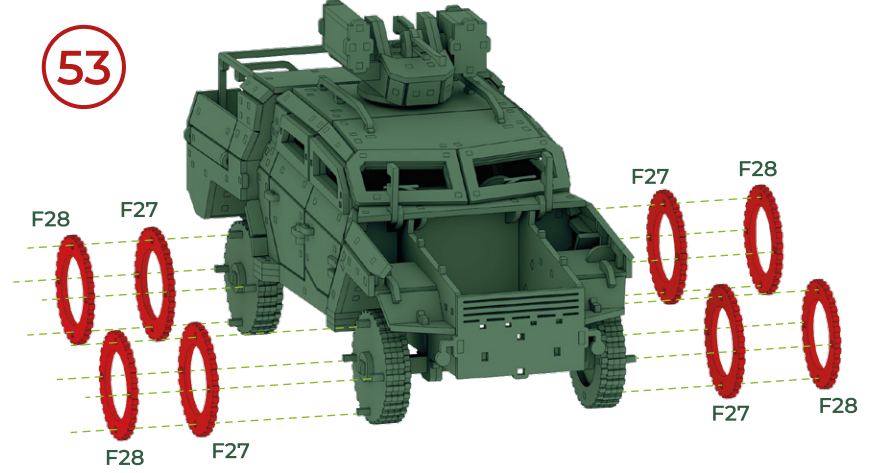

3-4
8

F28 (x4)
F27 (x4)

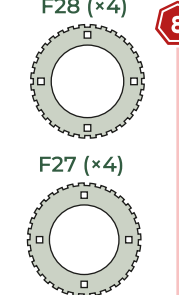

54

5

F31 (x2)



3
5

F32 (x2)



2
9

F29, F34



8

F30, F33

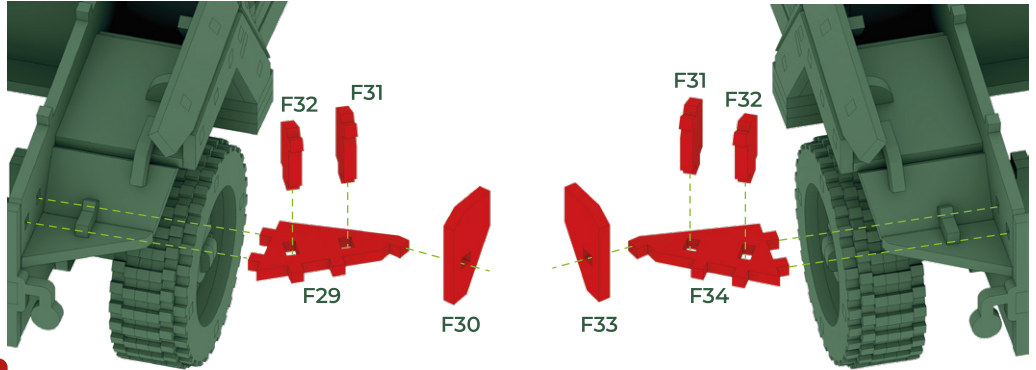

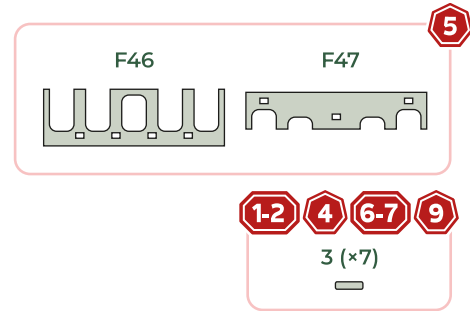
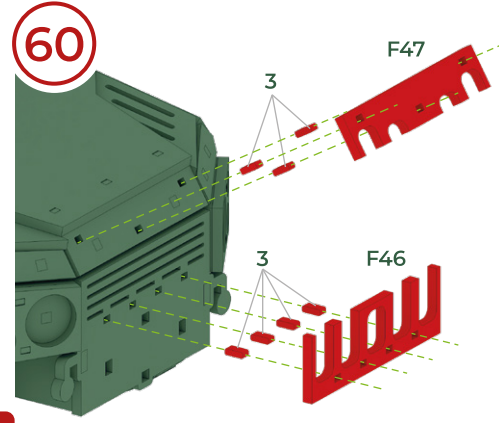
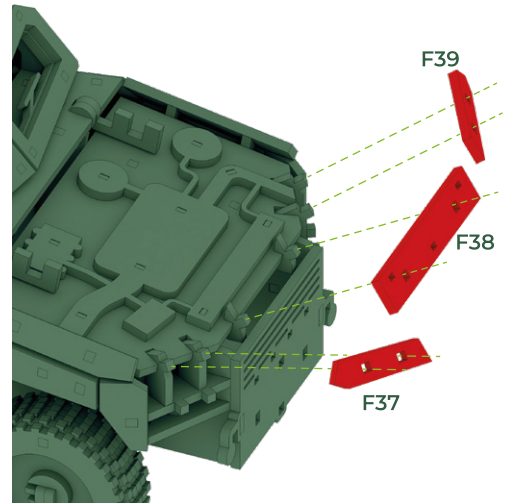
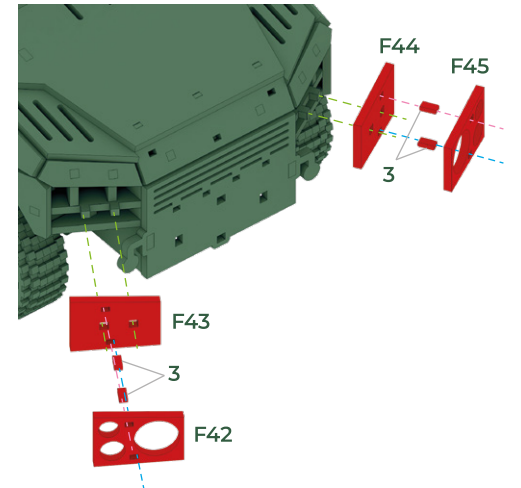
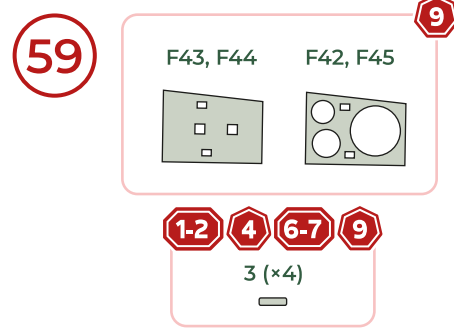
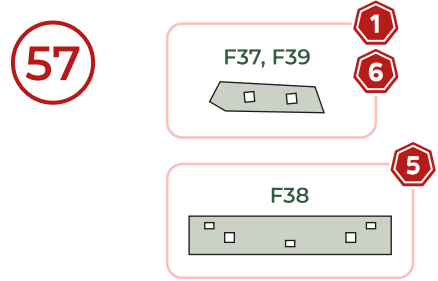
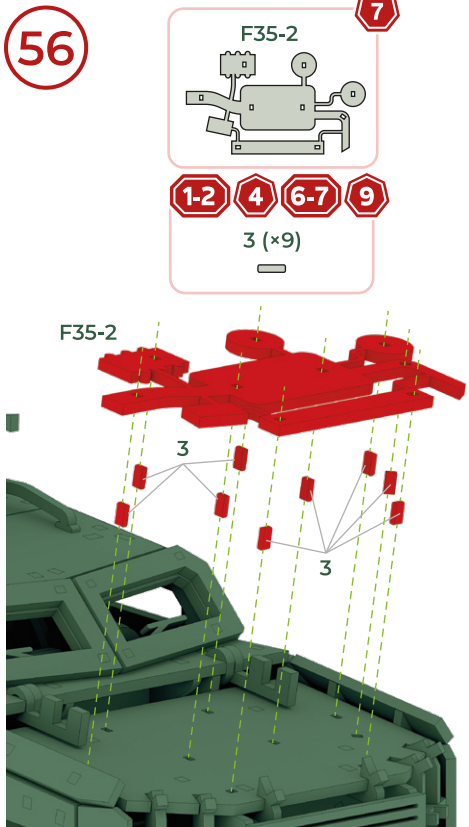
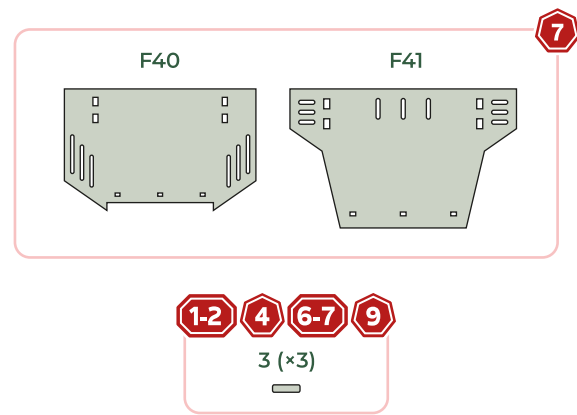
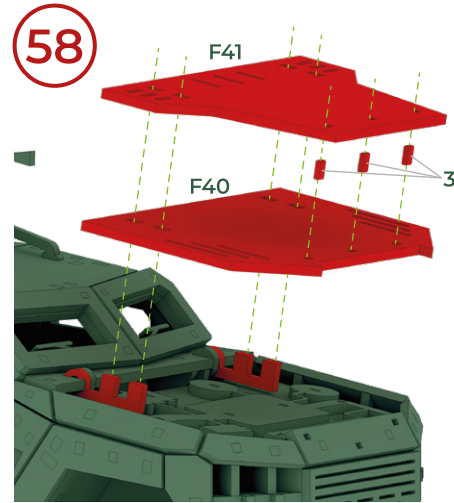
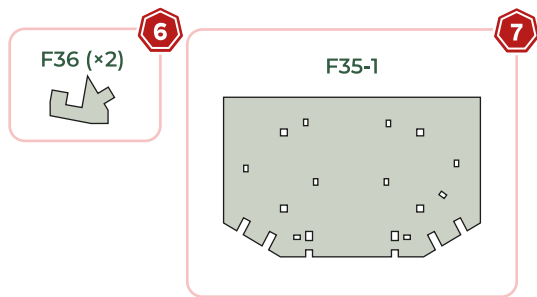
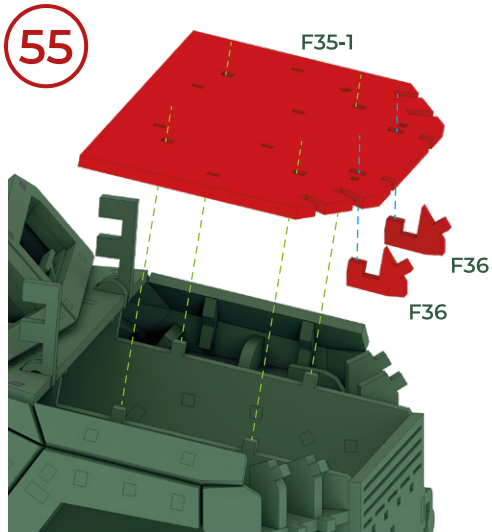

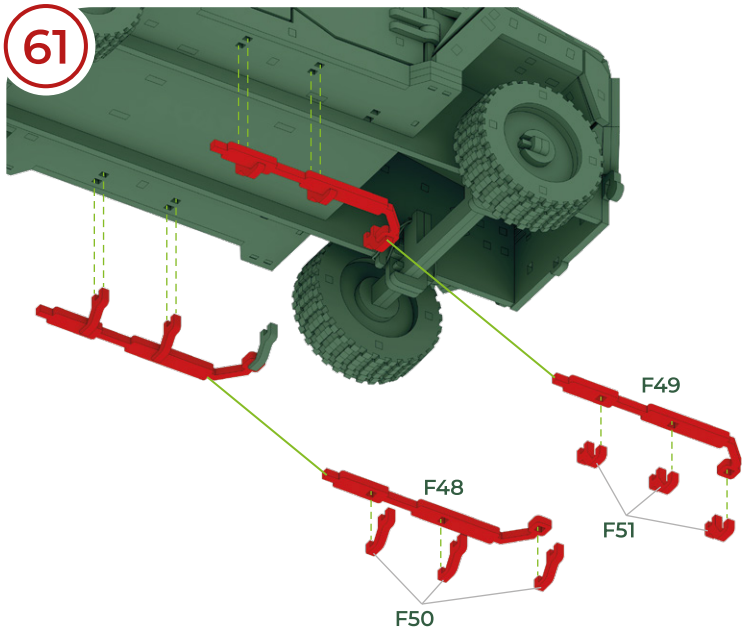
61

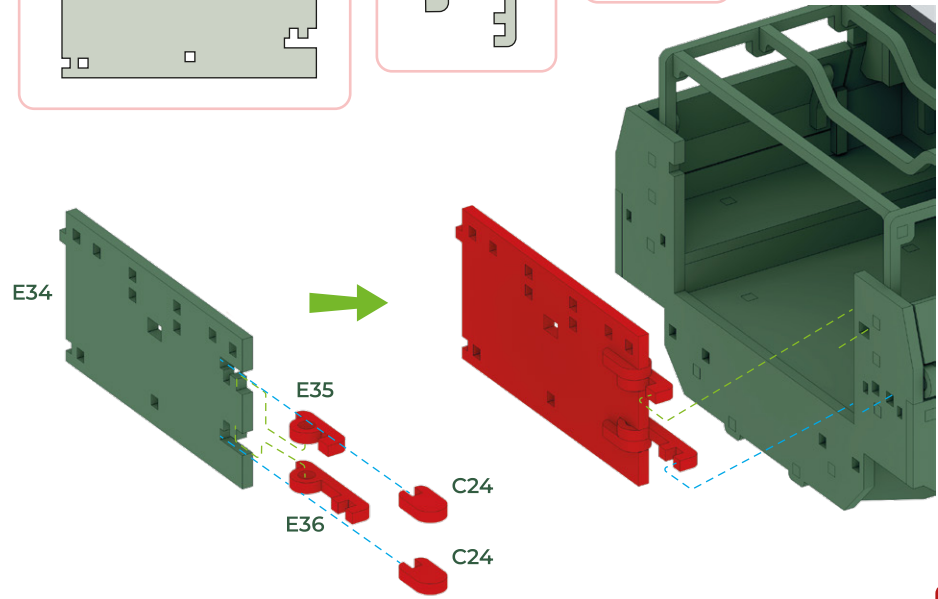
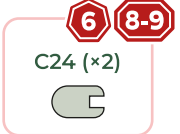
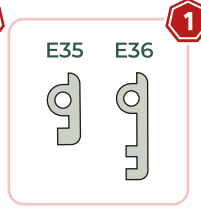
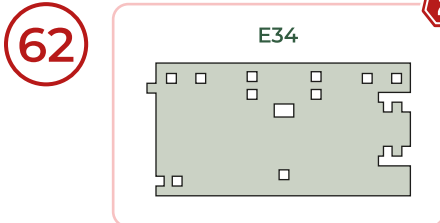
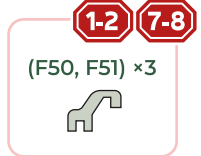
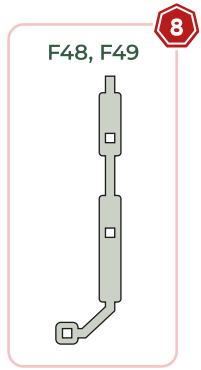

62

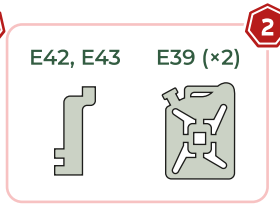
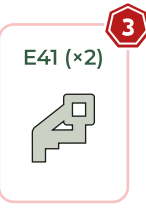
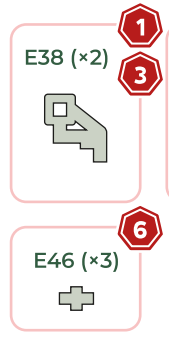
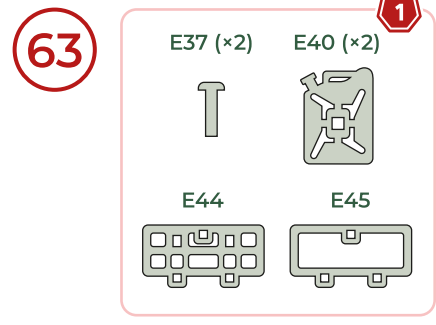

63

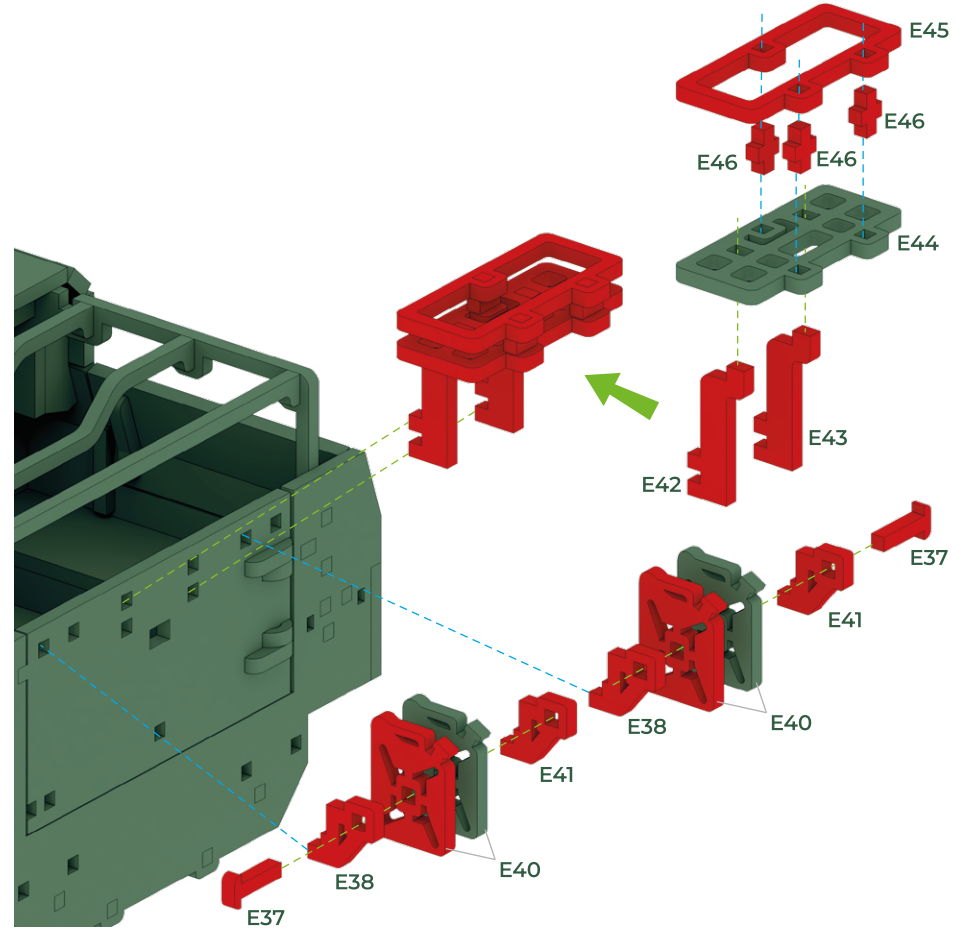

64

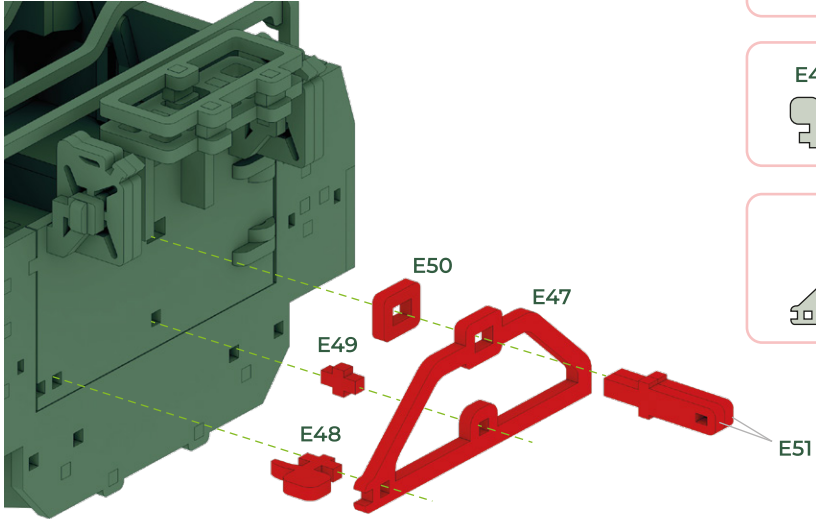

6 E49 +	4 E50 □
8 E48 +	8 E51 (x2) +
2 E47 +	

65

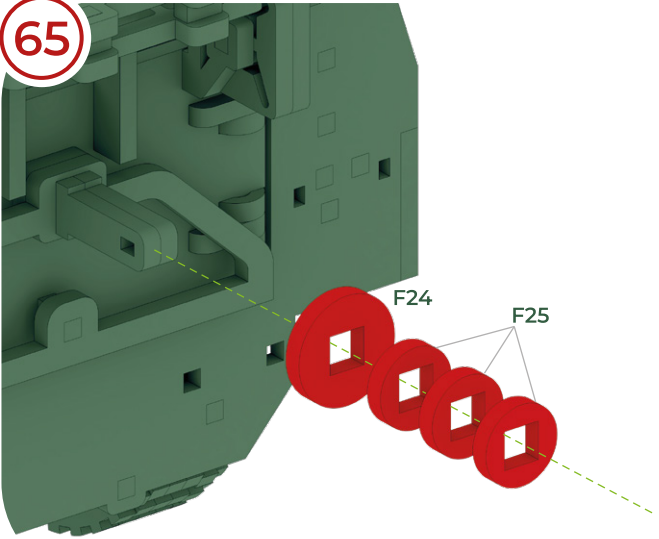

3 F24 □	4 F25 (x3) □
8	

66

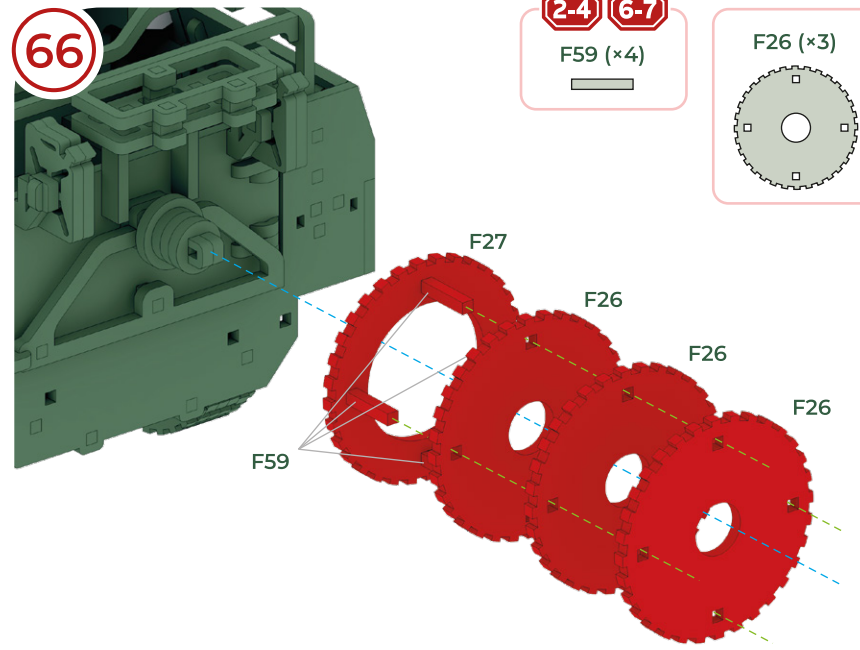

2-4 F59 (x4) —	6-7 F26 (x3) □	3-4 F27 □
8		

67

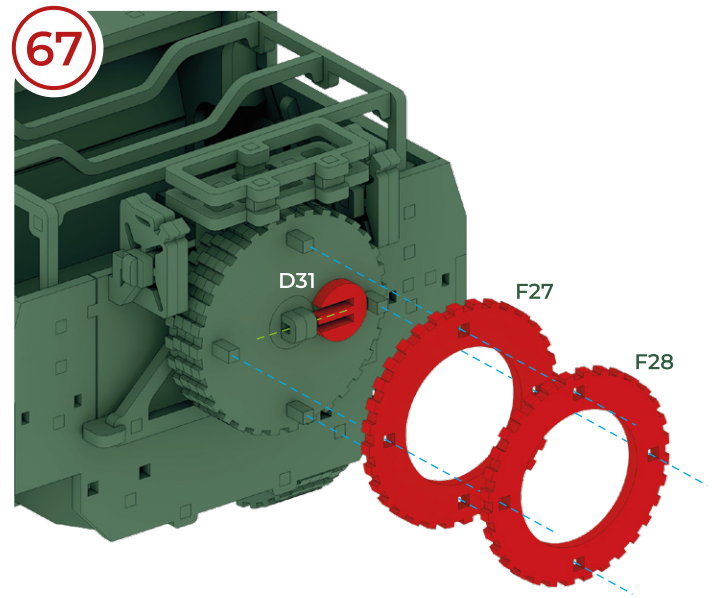

3-4 D31 □
3-4 F27 □
8 F28 □

68

(E55, E56) × 2 2-3

E57 (×2) 4-5

E58 (×2) 2

E52 (×2) 2
5

E53, E54 4

3 (×4) 1-2 4 6-7 9

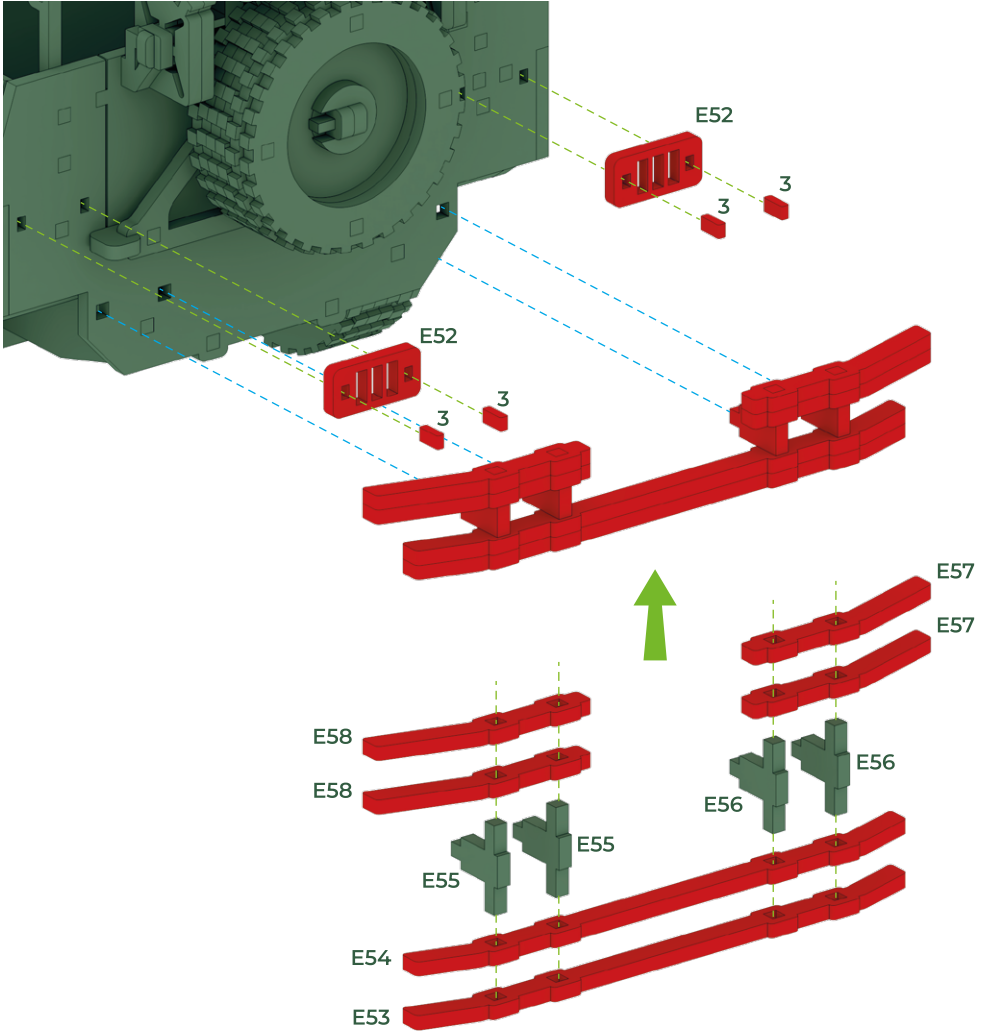

69

E59 7

E60 8

E61 4

E62, E63 5

E64 (×2) 3-4

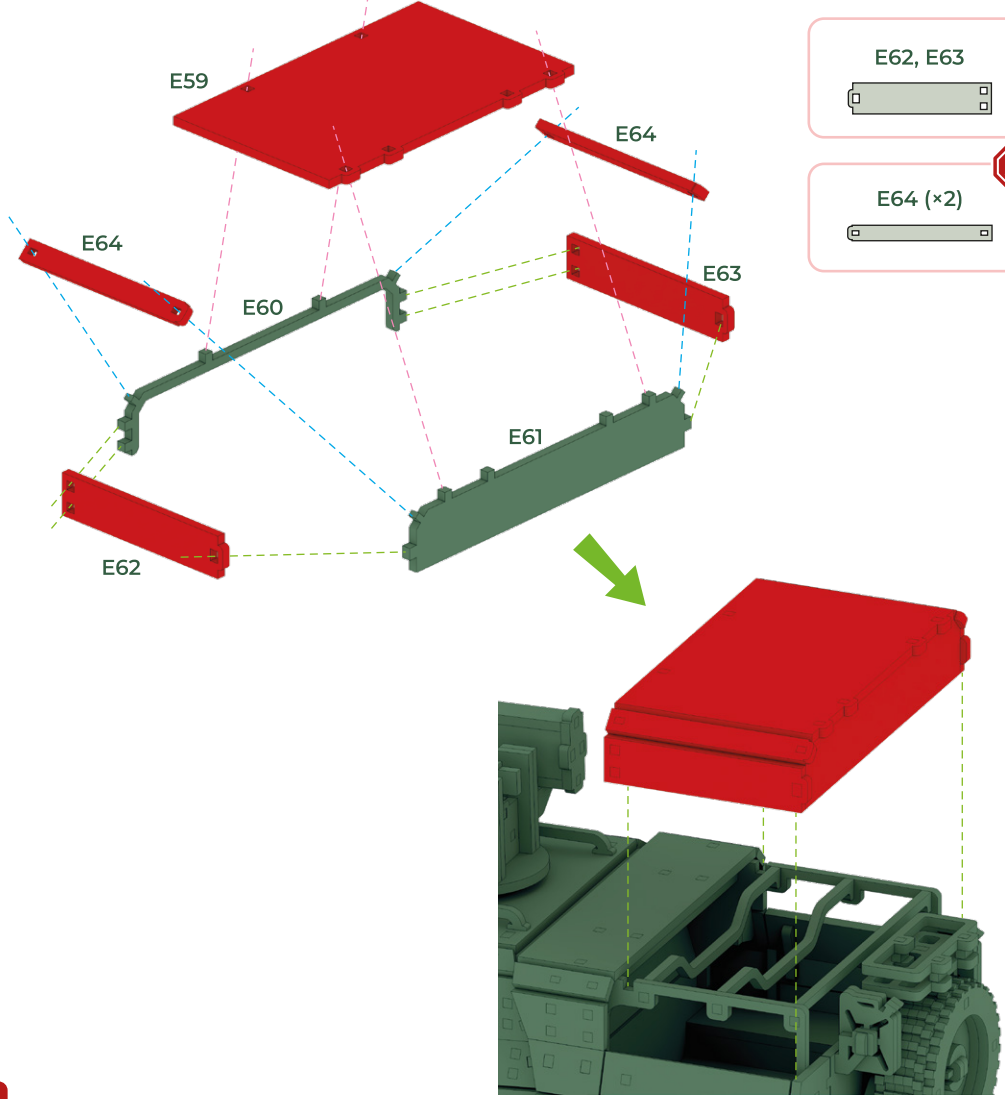

70

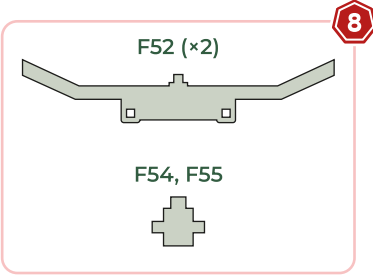

8

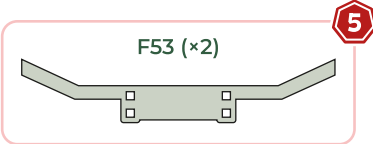

5

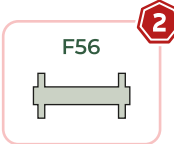

2

71

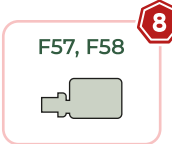

8

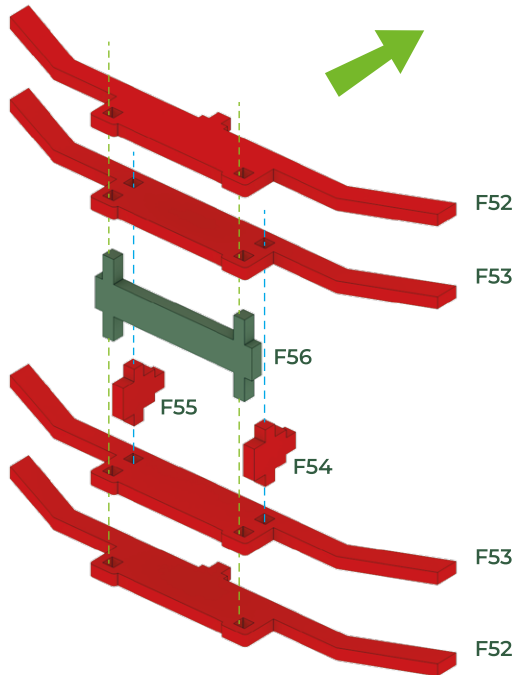
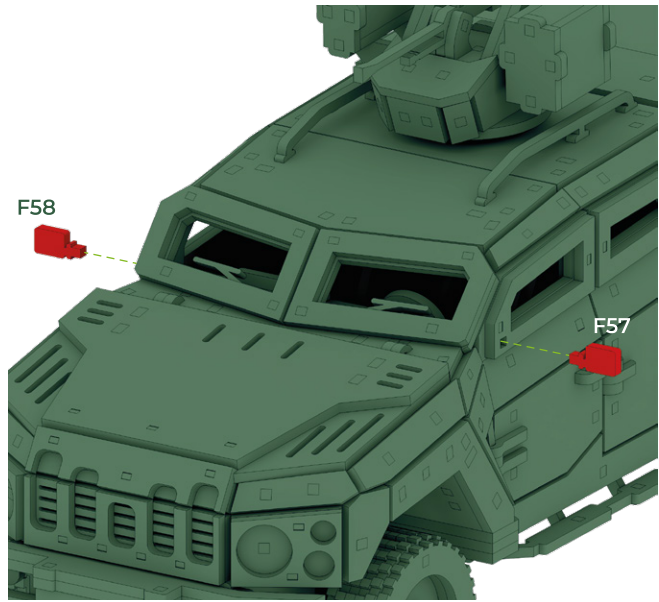
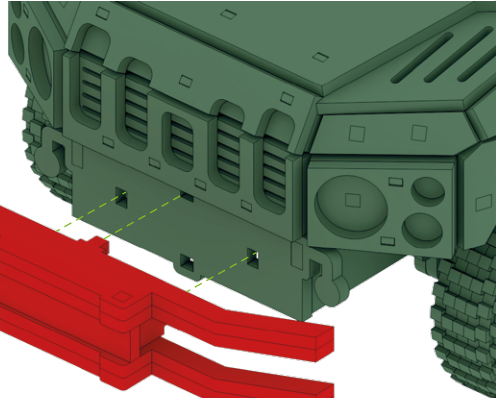

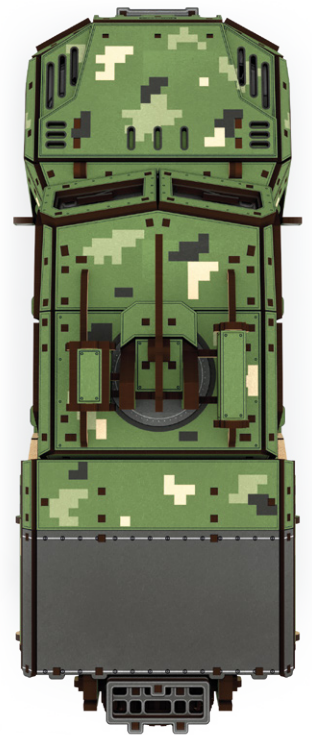
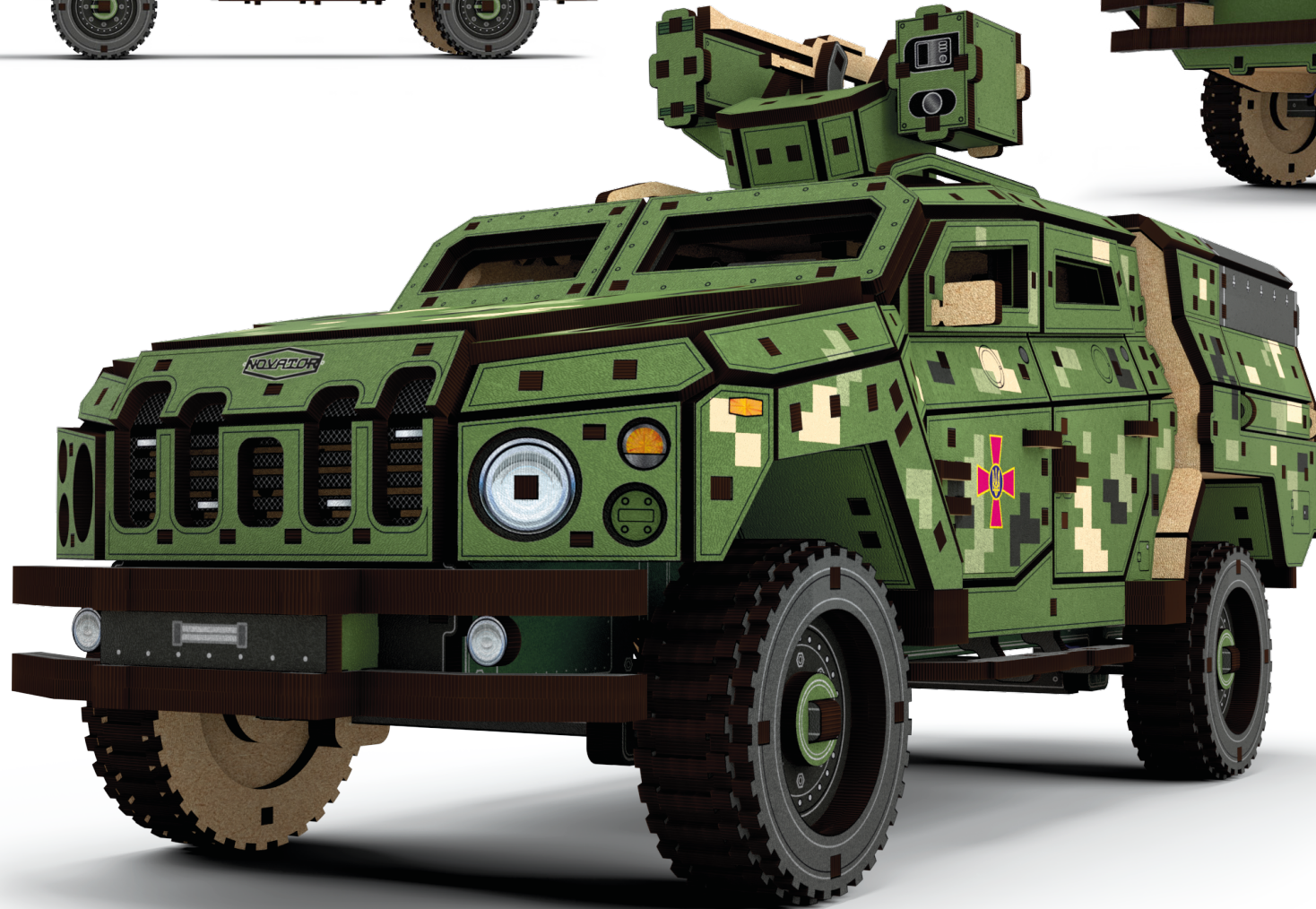
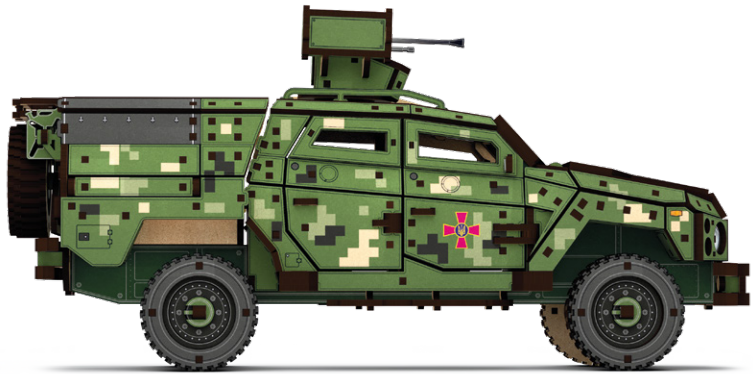



СПЕЦІАЛІЗОВАНИЙ БРОНЬОВАНИЙ АВТОМОБІЛЬ “NOVATOR”

NOVATOR & THE GRAVIX - це ліцензійний проект Конструкторсько-виробничого підприємства «Українська бронетехніка» та компанії THE GRAVIX. Проект створений задля популяризації українських виробів військового призначення.

“ NOVATOR “ – ЦЕ УНІВЕРСАЛЬНИЙ ЛЕГКИЙ ТАКТИЧНИЙ БРОНЬОВАНИЙ П'ЯТИМІСНИЙ КОЛІСНИЙ АВТОМОБІЛЬ ТИПУ «ПІКАП». ЗА СВОЇМ ФУНКЦІОНАЛОМ НИНІ ВІН ДУЖЕ КОРИСНИЙ ДЛЯ СИЛ ОБОРОНИ УКРАЇНИ.

На сьогодні NOVATOR активно застосовують підрозділи Збройних Сил України, Служби безпеки України та Національної гвардії. Завдяки швидкості та мобільності машини активно використовувалися під час звільнення Харківщини, Херсонщини. Нині ми знаємо, що автомобілі застосовуються для оборони Бахмута, Авдіївки, Кременної. За час активних бойових дій вони не раз потрапляли під ворожі обстріли — мінометні чи РСЗВ. Бронекапсула витримувала осколкові ураження, підриви протитанкових мін та рятувала життя екіпажу.

«Ми єдині, хто в Україні застосовує бронесталь такого типу...»

У рамках ініціативи, лідери продуктових категорій створюють унікальні вироби під ТМ “NOVATOR”, отримавши офіційну ліцензію. З кожного проданого продукту здійснюється відрахування до ТОВ «Українська бронетехніка» на виготовлення нової Зброї Перемоги.

